

# VA9104-xGA-3S Series Electric Non-Spring Return Valve Actuators

## Installation Instructions

VA9104-AGA-3S, VA9104-GGA-3S, VA9104-IGA-3S

Part No. 14-1336-23, Rev. A

Issued July 6, 2011

Supersedes December 5, 2005

Refer to the [QuickLIT Web site](#) for the most up-to-date version of this document.

### Applications

The VA9104 Series Actuators are direct-mount, non-spring return electric valve actuators that operate on AC 24 V power. These synchronous, motor-driven actuators are used to provide accurate positioning on Johnson Controls® VG1000 Series DN15, DN20, and DN25 (1/2, 3/4, and 1 in.) ball valves in Heating, Ventilating, and Air Conditioning (HVAC) applications.

The VA9104 Series Electric Non-Spring Return Actuators provide a running torque of 35 lb-in (4 N-m). The nominal travel time is 60 seconds at 60 Hz (72 seconds at 50 Hz) for 90° of rotation.

**IMPORTANT:** Use this VA9104 Series Electric Non-Spring Return Valve Actuator only to control valves under normal operating conditions. Where failure or malfunction of the VA9104 Series electric actuator could lead to personal injury or property damage to the controlled equipment or other property, additional precautions must be designed into the control system. Incorporate and maintain other devices, such as supervisory or alarm systems or safety or limit controls, intended to warn of or protect against failure or malfunction of the VA9104 Series electric actuator.

### Installation

Install the ball valve with the actuator at or above the centerline of the horizontal piping (Figure 1).

**IMPORTANT:** Before specifying VA9104 Series Electric Non-Spring Return Valve Actuators for plenum applications, verify acceptance of exposed plastic materials in plenum areas with the local building authority. Building codes for plenum requirements vary by location. Some local building authorities accept compliance to UL 1995, Heating and Cooling Equipment, while others use different acceptance criteria.

**IMPORTANT:** Do not install or use this VA9104 Series Electric Non-Spring Return Valve Actuator in or near environments where corrosive substances or vapors could be present. Exposure of the electric actuator to corrosive environments may damage the internal components of the device, and will void the warranty.

### Special Tool Needed

To install the actuator, use a digital voltmeter or M9000-200 Commissioning Tool.

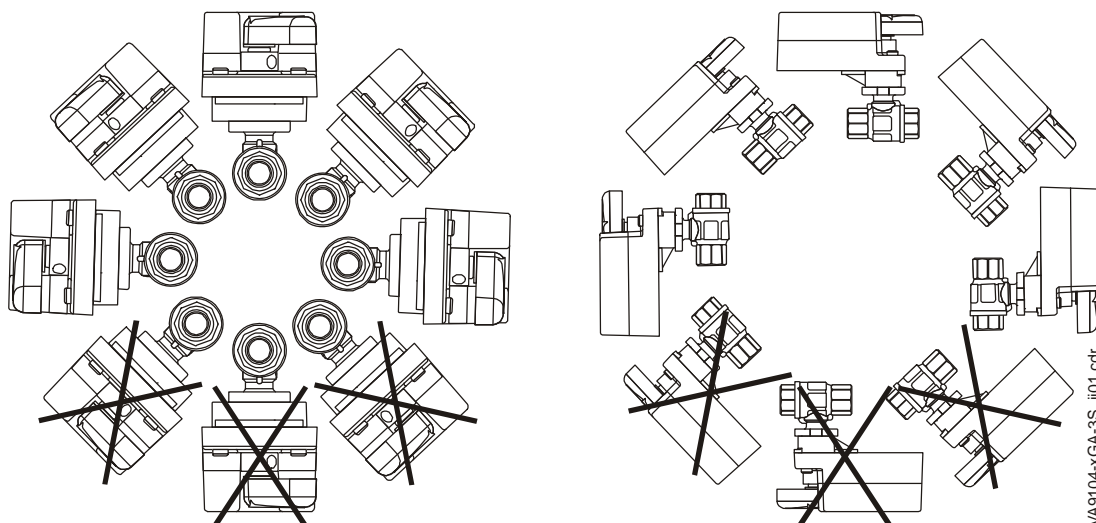
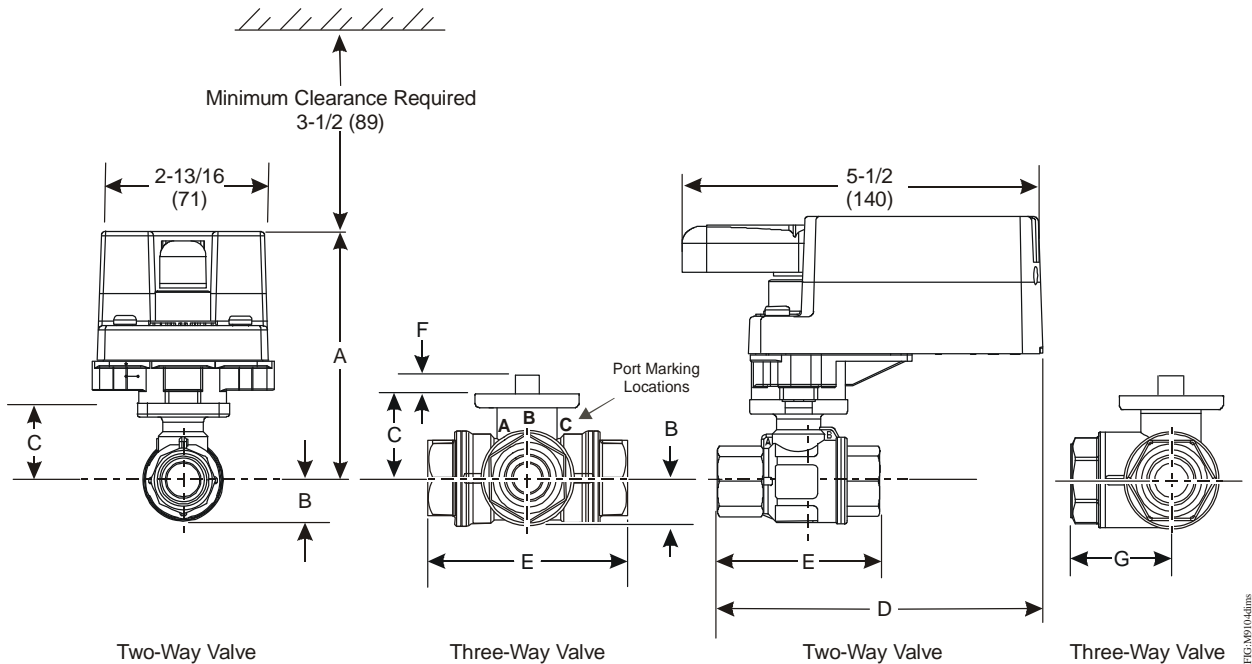

Figure 1: Mounting Positions for Chilled Water and Condensing Atmosphere Applications

## Dimensions

See Figure 2 for dimensions of the Non-Spring Return VA9104 Actuated VG1241, VG1245, VG1841, and VG1845 Series Ball Valve. See Table 1 for specific model dimensions.

See Table 2 for specific model dimensions for the VA9104 Actuated VG1275 and VG1875 Series Sweat End and the VA9104 Actuated VG1295 and VG1895 Series Press End Connection Ball Valves.



**Figure 2: VA9104 Series Electric Non-Spring Return Valve Actuator Dimensions, in. (mm)**

**Table 1: VA9104-xGx-3S Actuated VG1241, VG1245, VG1841, and VG1845 Series Ball Valve with Optional M9000-551 Linkage Dimensions, in. (mm)**

Valve Size, in. (DN) <sup>1</sup>	A	B	C	D	E	F	G
1/2 (DN15)	3-7/8 (98)	21/32 (17)	1-7/32 (31)	5-7/64 (129)	2-33/64 (64)	11/32 (9)	1-1/4 (32)
3/4 (DN20)	3-7/8 (98)	21/32 (17)	1-7/32 (31)	5-7/32 (133)	2-51/64 (71)	11/32 (9)	1-13/32 (36)
1 (DN25)	3-15/16 (100)	3/4 (19)	1-19/64 (33)	5-9/16 (141)	3-13/32 (87)	11/32 (9)	1-11/16 (43)

1. Port A must always be connected to the coil (Figure 2).

**Table 2: VA9104 Actuated VG1275 and VG1875 Series Ball Valve with Sweat End Connections and VA9104 Actuated VG1295 and VG1895 Series Ball Valves with Press End Connections Dimensions, in. (mm)**

Valve Size, in. (DN) <sup>1</sup>	A	B	C	D	E	F	G
1/2 (DN15)	3-7/8 (98)	21/32 (17)	1-7/32 (31)	5-45/64 (145)	3-25/32 (96)	11/32 (9)	2-13/16 (55)
3/4 (DN20)	3-7/8 (98)	21/32 (17)	1-7/32 (31)	5-57/64 (150)	4-3/32 (104)	11/32 (9)	2-15/32 (62)
1 (DN25)	3-15/16 (100)	3/4 (19)	1-19/64 (33)	6-1/8 (156)	4-21/32 (118)	11/32 (9)	2-27/32 (72)

1. Port A must connected to the coil (Figure 2).

See Figure 3 and Table 3 for VA9104 Valve Actuator dimensions with optional M9000-561 Thermal Barrier installed.

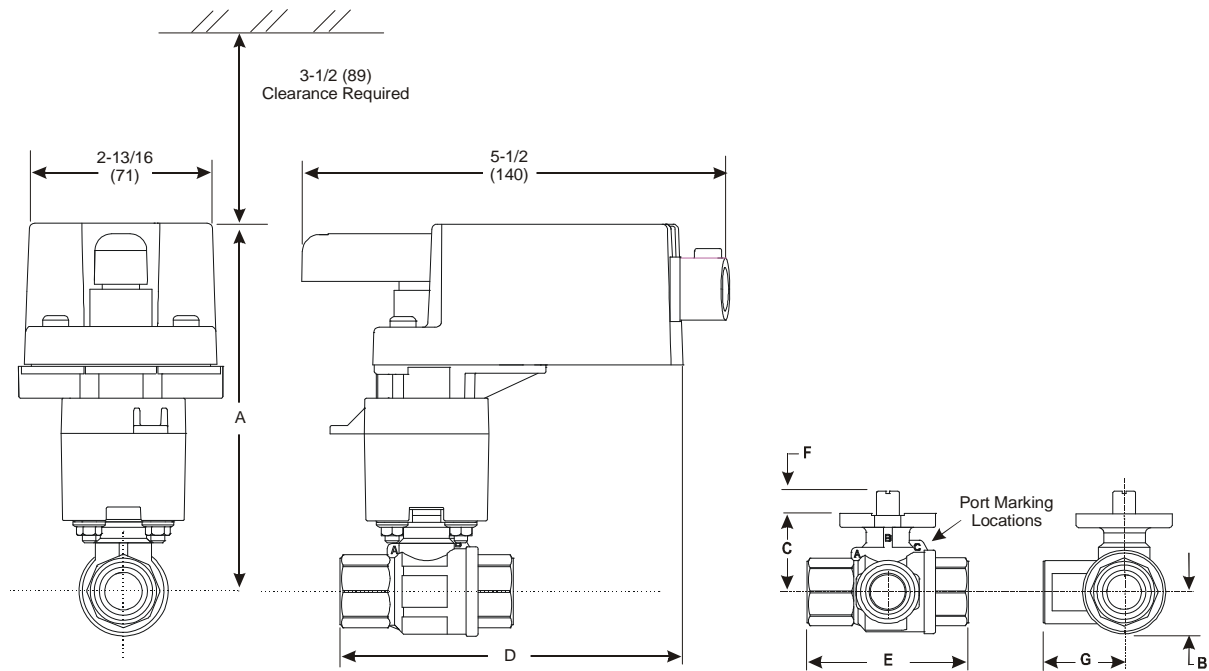

**Figure 3: Field-Installed VA9104 Series Electric Actuator Dimensions with Optional M9000-561 Thermal Barrier Dimensions, in. (mm)**

**Table 3: VA9104 Actuated VG1241, VG1245, VG1841, and VG1845 Series NPT Ball Valves with Optional M9000-561 Thermal Barrier Installed Dimensions, in. (mm)**

Valve Size, in. (DN) <sup>1</sup>	A	B	C	D	E	F	G
1/2 (DN15)	5-11/32 (135)	21/32 (17)	1-7/32 (31)	5-7/64 (129)	2-33/64 (64)	11/32 (9)	1-1/4 (32)
3/4 (DN20)	5-11/32 (135)	21/32 (17)	1-7/32 (31)	5-7/32 (133)	2-51/64 (71)	11/32 (9)	1-13/32 (36)
1 (DN25)	5-27/64 (137)	3/4 (19)	1-19/64 (33)	5-9/16 (141)	3-13/32 (87)	11/32 (9)	1-11/16 (43)

1. Port A must always be connected to the coil (Figure 2).

## Accessories

**Table 4: Accessories (Order Separately)**

Code Number	Description
<b>M9000-200</b>	Commissioning Tool that Provides a Control Signal to Drive 24 V On/Off, Floating, Proportional, and/or Resistive Electric Actuators
<b>M9000-561</b>	Thermal Barrier Extends M(VA)9104, M(VA)9203, and M(VA)9208 Series Electric Spring Return Actuator Applications to Include Low Pressure Steam (Quantity 1)
<b>M9000-341</b>	Weathershield Kit for VG1000 Series Ball Valve Application of M(VA)9104, M(VA)9203, and M(VA)9208 Series Electric Spring Return Actuators (Quantity 1)

## Mounting the Actuator

To mount the actuator:

1. Turn valve stem to position below.

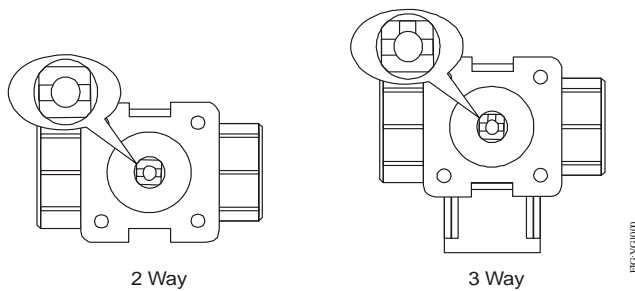

**Figure 4: Positioning the Valve Stem**

2. Mount optional M9000-561 Thermal Barrier to the valve if fluid temperature exceeds 212°F (100°C). See the *Mounting the Thermal Barrier* section for more information.
3. Place the handle the top of the drive shaft (Figure 5). The handle is keyed on and can only be mounted in one orientation.

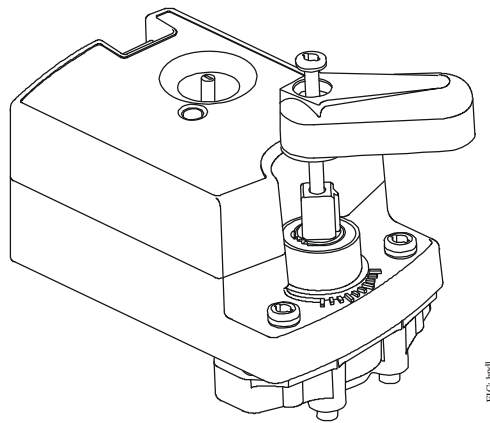

**Figure 5: Installing the Handle**

4. Check that the actuator coupler and handle are in the full counterclockwise position as viewed from the top of the actuator. If not, press the actuator gear release and rotate the handle until the actuator coupler is fully counterclockwise.
5. Install the valve actuator over the ball valve mounting flange. Depending on the installation, position the assembly in any one of four 90° increments on the valve.

**Note:** For proper operation, the actuator must drive the valve counterclockwise to open Port A when viewed from above the valve

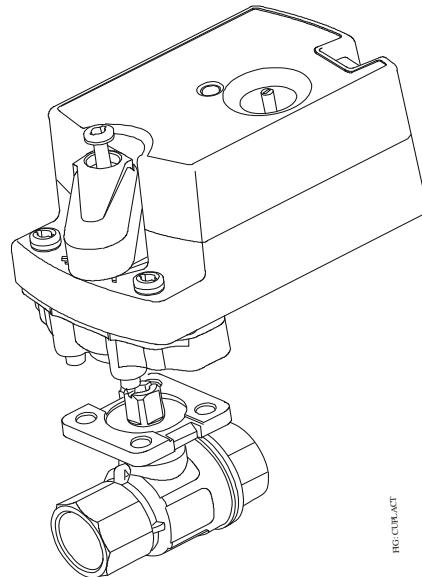

**Figure 6: Coupling the Actuator to the Valve**

6. To secure the actuator to the valve, use a 1/4 in. (6 mm) flat blade screwdriver. Recommended torque is 8 to 12 lb-in (0.9 to 1.4 N·m).

**IMPORTANT:** Do not overtighten the manual handle mounting screw. Overtightening may strip the threads resulting in damage to the valve stem threads.

## Mounting the Thermal Barrier

Figure 7 shows the optional M9000-561 Thermal Barrier.

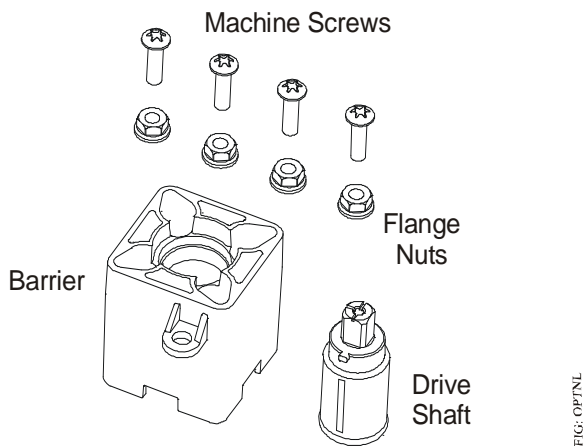

**Figure 7: Optional M9000-561 Thermal Barrier**

To mount the optional thermal barrier:

1. Install the thermal barrier drive shaft into the thermal barrier by aligning the tab on the drive shaft with the slot on the thermal barrier (Figure 8).

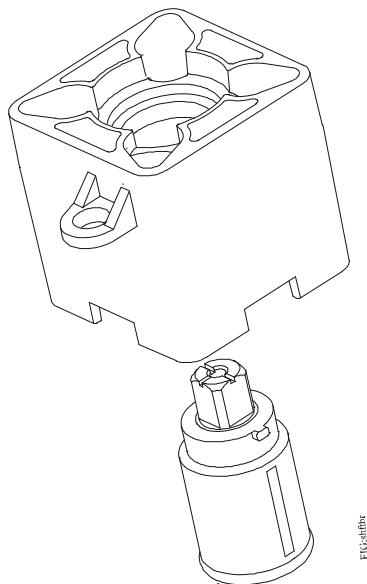

**Figure 8: Installing the Drive Shaft into the Thermal Barrier**

2. Rotate the drive shaft to align marks on the top of the thermal drive shaft with matching marks on the valve stem.
3. Mount the thermal barrier onto the valve using the four included M5x16 mm machine screws and four M5 flange nuts. Tighten the screws to a recommended torque of 21 to 25 lb-in. (2.4 to 2.8 N·m) (Figure 9).

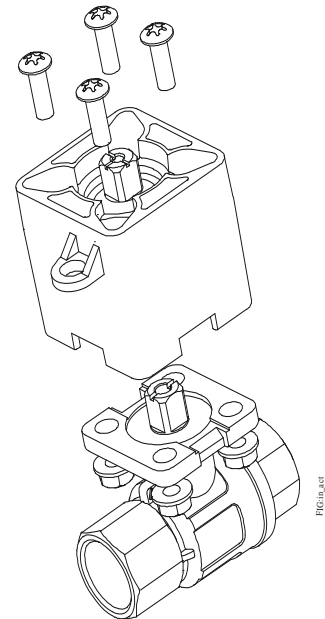

**Figure 9: Installing the Barrier**

4. Proceed to *Mounting the Actuator*. Follow the same steps as mounting directly to the valve when mounting the actuator to the thermal barrier.

## Wiring



### WARNING: Risk of Electric Shock.

Disconnect or isolate all power supplies before making electrical connections. More than one disconnect or isolation may be required to completely de-energize equipment. Contact with components carrying hazardous voltage can cause electric shock and may result in severe personal injury or death.



### CAUTION: Risk of Property Damage.

Do not apply power to the system before checking all wiring connections. Short circuited or improperly connected wires may result in permanent damage to the equipment.



### CAUTION: Risk of Property Damage.

Insulate and secure each unused wire lead before applying power to the actuator. Failure to insulate and secure each unused wire lead may result in property damage.

**IMPORTANT:** Make all wiring connections in accordance with the National Electrical Code and local regulations. Use proper Electrostatic Discharge (ESD) precautions during installation and servicing to avoid damaging the electronic circuits of the actuator.

### VA9104-AGA-3S and VA9104-IGA-3S

The VA9104-AGA and VA9104-IGA Series Electric Non-Spring Return Valve Actuators require an AC 24 V input signal and work with a variety of controllers. These electric actuators include M3 Screw terminals; see Figure 10 and Figure 11 to wire the applicable VA9104 Series model.

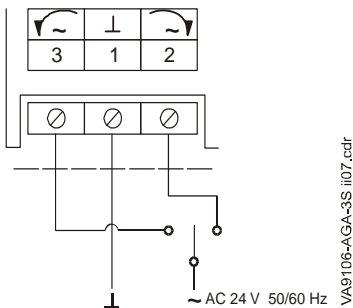

Figure 10: VA9104-AGA-3S Control Wiring Diagram

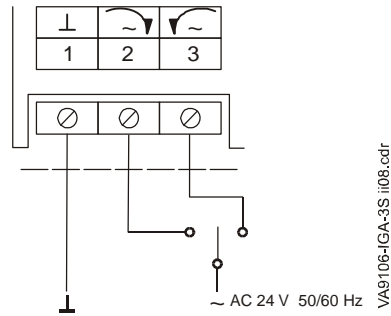
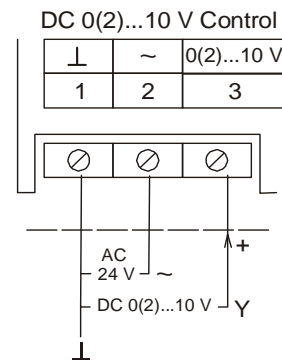

Figure 11: VA104-IGA-3 Control Wiring Diagram

**Note:** For all VA9104-AGA Series Actuators, use a controller and/or software that provides a timeout function at the end of rotation (stall) to avoid excessive wear or drive time on the actuator motor. The -GGA and -IGA models have an auto shutoff feature to prevent excessive wear or drive time on the motor.

### VA9104-GGA-3S

The VA9104-GGA Series Electric Non-Spring Return valve actuators require AC 24 V power and a DC 0(2) to 10 V or 0(4) to 20 mA controller input signal. These electric actuators include M3 screw terminals; see Figure 12 for proper wiring.



### 0(4)...20 mA Control with External Resistor

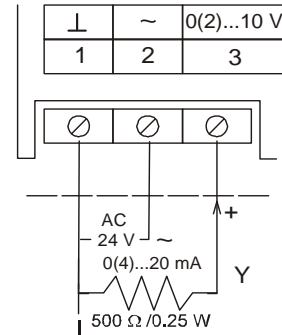

Figure 12: VA9104-GGA-3S Control Wiring Diagram

**VA9104-GGA** actuators are factory set for Direct Acting (DA) mode and for a DC 0 to 10 V input control signal. In DA mode, a minimum control signal drives the actuator to the full Counterclockwise (CCW) position, and a maximum control signal drives the actuator to the full Clockwise (CW) position.

For Reverse Acting (RA) operation, a minimum control signal drives the actuator to the full CW position and a maximum signal drives the actuator to the full CCW position. To change the factory settings, remove the actuator cover and adjust the switches on the circuit board as shown in Figure 13.

### Setup and Adjustments

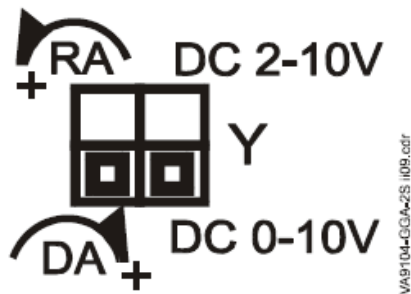



Figure 13: VA9104-GGA Factory Switch Setting



**CAUTION: Risk of Electric Shock.**  
Disconnect the power supply before making electrical connections to avoid electric shock.

### Commissioning

After wiring is complete, apply power and provide input signals to the actuator to drive it at least one complete cycle open and closed.

### Technical Specifications

#### VA9104-xGA-3S Series Electric Non-Spring Return Valve Actuators (Part 1 of 2)

<b>Power Requirements</b>		AC 24 V +25%/-20% at 50/60 Hz, 2.3 VA (AGA), 3.6 VA (GGA), and 3.0 VA (IGA) Supply, Class 2 or Safety Extra-Low Voltage (SELV)
<b>Control Type</b>	<b>VA9104-AGA-3S</b>	Floating or On/Off Control without Timeout
	<b>VA9104-GGA-3S</b>	Proportional Control
	<b>VA9104-IGA-3S</b>	Floating or On/Off Control with Timeout
<b>Input Signal</b>	<b>VA9104-AGA-3S</b>	AC 24 V +25%/-20% at 50/60 Hz, Class 2 or SELV without Timeout
	<b>VA9104-GGA-3S</b>	DC 0 (2) to 10 V or 0 (4) to 20 mA with Field-Furnished 500 Ohm Resistor
	<b>VA9104-IGA-3S</b>	AC 24 V +25%/-20% at 50/60 Hz, Class 2 or SELV with Timeout
<b>Motor Input Impedance</b>	<b>VA9104-AGA-3S</b>	200 ohms Nominal
<b>Control Input Impedance</b>	<b>VA9104-GGA-3S</b>	Voltage Input: 200,000 ohm Current Input: 500 ohms with field-furnished 500 ohm resistor

### Troubleshooting

If the VA9104 Series Electric Non-Spring Return Valve Actuator is not responding or working properly:

- Verify that the actuator assembly is properly secured to the valve.
- Check that all electrical connections are complete and that power is applied.
- Verify that the valve fully opens and closes, using the gear release button on the actuator and the manual override handle.

### Repairs and Replacement

If the VA9104 Series Electric Non-Spring Return Actuator fails to operate within its specifications, replace the unit. For a replacement electric actuator, contact the nearest Johnson Controls representative.

## VA9104-xGA-3S Series Electric Non-Spring Return Valve Actuators (Part 2 of 2)

<b>Running Torque</b>		35 lb-in. (4 N·m)
<b>Travel Time</b>		60 Seconds at 60 Hz (72 Seconds at 50 Hz) for 90° of Rotation
<b>Rotation Range</b>		93° ±3°, CW or CCW
<b>Cycles</b>		100,000 Full Stroke Cycles; 2,500,000 Repositions at Rated Running Torque
<b>Audible Noise Rating</b>		35 dBA Nominal at 39-13/32 in. (1 m)
<b>Electrical Connections</b>	<b>VA9104-xGA-3S</b>	M3 Screw Terminals
<b>Enclosure</b>	<b>VA9104-xGA-3S</b>	NEMA 2, IP42
<b>Ambient Conditions</b>	<b>Operating</b>	-4 to 140°F (-20 to 60°C); 90% RH Maximum, Noncondensing
	<b>Storage</b>	-20 to 150°F (-29 to 66°C); 90% RH Maximum, Noncondensing
<b>Fluid Temperature Limits (Actuator and Valve Assembly)</b>	<b>VG12x1 and VG18x1 Series</b>	23 to 203°F (-5 to 95°C)
	<b>VG1245 and VG1845 Series</b>	-22 to 212°F (-30 to 100°C)
	<b>VG12x5 and VG18x5 Series with M9000-561 Thermal Barrier</b>	-22 to 284°F (-30 to 140°C) Water; 15 psig (103 kPa) at 250°F (121°C) Saturated Steam
<b>Compliance</b>  	<b>United States</b>	UL Listed, CCN XAPX, File E27734; to UL 60730-1A: 2003-08, Ed. 3.1, Automatic Electrical Controls for Household and Similar Use; and UL 60730-2-14: 2002-02, Ed. 1, Part 2 Particular Requirements for Electric Actuators (All Models) Actuator Housing is Plenum Rated per CSA C22.2 No. 236/UL 1995, Heating and Cooling Equipment
	<b>Canada</b>	UL Listed, CCN XAPX7, File E27734; to UL 60730-1:02-CAN/CSA: July 2002, 3rd Ed., Automatic Electrical Controls for Household and Similar Use; and CSA C22.2 No. 24-93 Temperature Indicating and Regulating Equipment (All Models) Actuator Housing is Plenum Rated per CSA C22.2 No. 236/UL 1995, Heating and Cooling Equipment
	<b>Europe</b>	CE Mark – Johnson Controls, Inc., declares that this product is in compliance with the essential requirements and other relevant provisions of the EMC Directive 2004/108/EC and the Low Voltage Directive 2006/95/EC.
	<b>Australia and New Zealand</b>	C-Tick Mark, Australia/NZ Emissions Compliant
<b>Shipping Weight</b>		1.25 lb (0.55 kg)

The performance specifications are nominal and conform to acceptable industry standards. For application at conditions beyond these specifications, consult the local Johnson Controls office. Johnson Controls, Inc. shall not be liable for damages resulting from misapplication or misuse of its products.



**Building Efficiency**

507 E. Michigan Street, Milwaukee, WI 53202

Metasys® and Johnson Controls® are registered trademarks of Johnson Controls, Inc.  
All other marks herein are the marks of their respective owners. © 2011 Johnson Controls, Inc.