

## EPP-1000 Electro-Pneumatic Positioner

*The EPP-1000 provides accurate electronic positioning control and position feedback for pneumatic valve and damper actuators. It accepts analog control signals provided by function modules, System 350™ components, and many other generic controllers.*



**Figure 1: The EPP-1000**

### Features and Benefits

<input type="checkbox"/> <b>Quick-Release Mounting Clamp, Valve Actuator and Damper Actuator Mounting Hardware, Terminal Block Wiring, and a Conduit-Friendly Enclosure</b>	Allows quick, easy installation and wiring directly to the actuator--saving time and money
<input type="checkbox"/> <b>Potentiometers for Adjustment of Offset, Span, Home, and Stroke</b>	Provides the flexibility to tailor Offset and Span for a given application. Allows for setting of the minimum and maximum limits on actuator travel. Makes actuator sequencing off of one signal easy
<input type="checkbox"/> <b>Accepts 0 to 10 Volt, 4 to 20 Milliamp, and 135 Ohm Slidewire Input Control Signals</b>	Offers input signal compatibility with a wide variety of controllers
<input type="checkbox"/> <b>Optional Separate 10K Ohm Feedback Pot</b>	Provides a separate output for position feedback to the controller or other devices
<input type="checkbox"/> <b>Actuator Mounted, Uses Analog Control Signals Direct from a Controller or FM-OAE Function Module</b>	Reduces panel or function module kit slots taken up by output devices and reduces dependence on 2-slot FM-OAP function modules
<input type="checkbox"/> <b>Supply and Exhaust LED Indicators</b>	Assists in setting home and stroke; reduces time spent on commissioning
<input type="checkbox"/> <b>Power-off Return to Normal Characteristic</b>	Allows actuator to return to normal position (based on spring return) upon power failure

## Product Overview

The EPP-1000 provides accurate and precise electronic control of pneumatic damper and valve actuator position. The Electro-Pneumatic Positioner (EPP) requires 20 to 30 VAC and 20 psig supplies and accepts voltage, current, or resistance (slidewire) control signals. The output is a pneumatic signal to the actuator, which is selectable as direct acting or reverse acting. Additional models are available with a separate 10K ohm potentiometer, which can be used to provide position information to a controller or other devices. The EPP-1000 is a non-bleed type device, which may allow for smaller compressors in some applications.

The EPP is factory calibrated for a 1 volt offset and an 8 volt span and is field adjustable for applications that require different settings. Home and stroke settings, which define minimum and maximum limits on actuator travel, are easily adjustable and can be established without input signals from the controller. Upon loss of power, the EPP-1000 will default to its zero pressure position allowing the actuator to return to its normal state.

The EPP-1000 is designed for direct mounting to Johnson Controls pneumatic damper and valve actuators and is available in six different models depending on mounting configuration and feedback requirements. Refer to *Ordering Information*, for the list of specific code numbers and their descriptions.

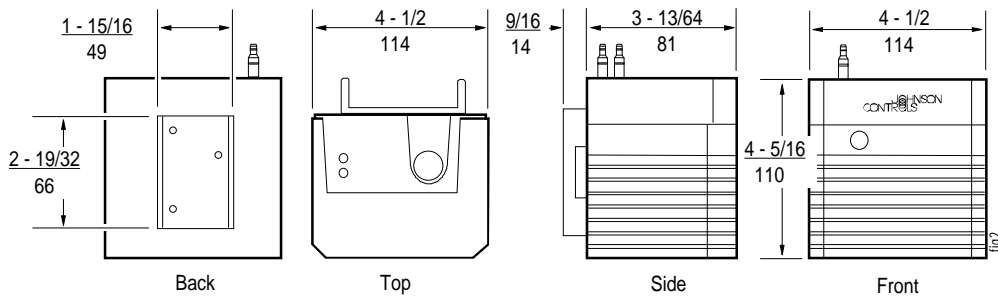
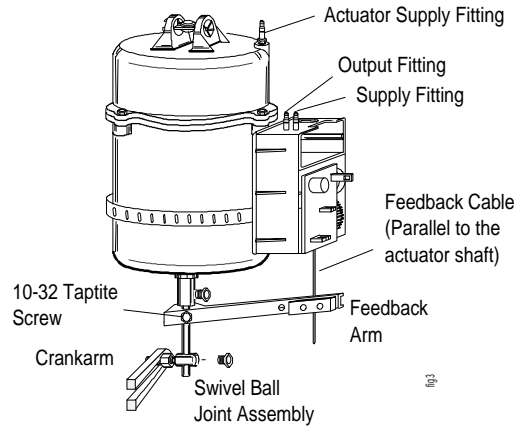

Figure 2: EPP-1000 Dimensions (in./mm)

## Theory of Operation

The EPP-1000 operates by comparing two signals--the analog input control signal provided by the controller and the actuator position signal generated from the feedback arm and cable assembly connected to the actuator shaft. These two signals are conditioned and fed into a comparator. If the signals do not match, i.e., if the position of the shaft does not match the input control signal, the comparator energizes a solenoid air valve to either supply additional air to or exhaust air from the pneumatic actuator. As the air supply to the actuator is varied,

movement occurs in the actuator shaft, thereby changing the actuator position signal fed into the comparator. This continues until the position signal corresponds to the input signal. At that time, the comparator will close the solenoid air valve, locking the actuator into position. For models with the additional feedback potentiometer, the potentiometer provides a resistance signal directly proportional to the position of the actuator shaft as indicated by the feedback cable assembly.



**Figure 3: EPP-1000, with Cover Off, Mounted on a Damper Actuator**

## Application Information

The EPP-1000 is designed for applications where electronic control of pneumatic actuators is desired--particularly in instances where there is a need for accurate or precise actuator positioning. Typical applications include control of damper actuators, inlet guide vanes and valve actuators on air handling units, large commercial unitary equipment (such as rooftops), mixing plenums, and chilled water systems. Models with a feedback pot may be used to provide information for use in monitoring or documenting damper positions. Additionally, multiple EPPs may be sequenced off of a single control signal through the use of staggered offset and span

settings. The EPP can also be used in electronic retrofits of pneumatic systems.

The EPP-1000 mounts directly to the controlled device (actuator) through a quick release clamp, which provides the flexibility to adapt to differently shaped actuator housings (Figure 3). The unit enclosure has provisions to accept a conduit connector, and wiring connections are made to a terminal block. Pneumatic connections are made to two barbed fittings on the exterior of the enclosure. The feedback cable connects the EPP and the actuator shaft through a feedback arm assembly that is directly coupled to the actuator shaft.

## Ordering Information

Product Code No.	Description
<b>EPP-1000-11</b>	Electro-Pneumatic Positioner; 5R or 8R Valve Actuator Mounting Kit
<b>EPP-1000-12</b>	Electro-Pneumatic Positioner; 4R Valve Actuator Mounting Kit
<b>EPP-1000-13</b>	Electro-Pneumatic Positioner; Damper Actuator Mounting Kit
<b>EPP-1000-21</b>	Electro-Pneumatic Positioner with feedback; 5R or 8R Valve Actuator Mounting Kit
<b>EPP-1000-22</b>	Electro-Pneumatic Positioner with feedback; 4R Valve Actuator Mounting Kit
<b>EPP-1000-23</b>	Electro-Pneumatic Positioner with feedback; Damper Actuator Mounting Kit
<b>EPP-1000-601</b>	Cable Replacement Kit

## Application Identification

EPP-

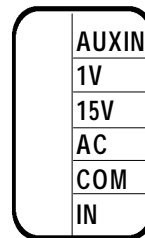

See BEIMS 45—2.03—1

# Specifications

<b>Product</b>	EPP-1000 Electro-Pneumatic Positioner	
<b>Power Requirements</b>		
<b>Pneumatic Air Supply</b>	25 psig maximum	
<b>Electrical</b>	20 to 30 VAC; 50/60 Hz (product can also be powered with 22 to 30 VDC by connecting power supply positive to "AC" and power supply negative to "COM")	
<b>Wiring Connections</b>		
Screw terminals		
<b>Pneumatic Connections</b>		
Barbed fittings for 5/32 or 1/4 in. O.D. polytubing		
<b>Input Signal</b>	"IN"	30 VDC maximum
	"AUX IN"	Voltage configuration = 3 VDC maximum
		Current configuration = 30 mA maximum
	Slidewire control = 135 to 1000 ohms	
<b>Impedance</b>	"IN"	27K ohms
	"AUX IN"	Voltage configuration = 3K ohms (current configuration = 100 ohms)
<b>Adjustments</b>		
<b>Home</b>	Allows the minimum position of the actuator to be adjusted between 0 and 33% of full stroke	
<b>Stroke</b>	Allows full stroke to be adjusted between 33 and 100% of total feedback potentiometer stroke	
<b>Offset</b>	Allows adjustment of input signal level at which the actuator starts to move from the home position	
<b>Span</b>	Allows adjustment of the input signal level at which the actuator reaches its full stroke	
<b>Range of Adjustments</b>	<b>Home, Stroke, Offset</b>	<b>Span</b>
<b>IN</b>	0 to 22.5 VDC	1-18 VDC
<b>AUX IN</b>	(Voltage) 0 to 2.5 VDC	0.1 to 2 VDC
	(Current) 0 to 25 mA	1 to 20 mA
	(Slidewire) 0 to 100%	10 to 100% of slidewire
<b>Feedback Potentiometer</b>	(EPP-1000-21, 22, 23 only) 10K ohm linear taper potentiometer	
<b>Ambient Operating</b>	-20 to 150°F (-29 to 65°C)	
<b>Ambient Storage</b>	-20 to 167°F (-29 to 75°C)	
<b>Humidity</b>	Maximum 95% RH limited to 85°F maximum dew point	
<b>Hysteresis</b>	3% of span	
<b>Linearity</b>	5% of span	
<b>Flow Characteristics</b>	20 psi; 476 scim	
<b>Agency Compliance</b>	UL listed; CSA approved	
<b>Dimensions (H x W x D)</b>	4-5/16 x 4-1/2 x 3-13/64 in. (110 x 114 x 81 mm)	
<b>Shipping Weight</b>	1.6 lb (0.74 kg)	

*The performance specifications are nominal and conform to acceptable industry standards. For application at conditions beyond these specifications, consult the local Johnson Controls office. Johnson Controls, Inc. shall not be liable for damages resulting from misapplication or misuse of its products.*



**Controls Group**  
 507 E. Michigan Street  
 P.O. Box 423  
 Milwaukee, WI 53201

Printed in U.S.A.