

M100G Series Proportional Actuator with VDC/mA Control Input R81GAA-2 Interface Board

Installation

IMPORTANT: All M100G Series actuators are intended to control equipment under normal operating conditions. Where failure or malfunction of M100G actuators could lead to an abnormal operating condition that could cause personal injury or damage to the equipment or other property, other devices (limit or safety controls) or systems (alarm or supervisory) intended to warn of, or protect against, failure or malfunction of M100G actuators must be incorporated into and maintained as part of the control system.

Parts Included

- M100G proportional spring return or non-spring return actuator (R81GAA-2 electronics installed)
- five 1/4 in. female quick-connect terminals
- one 1/4 in. male/female quick-connect terminal
- LVR27A-602 crank arm (only included with the spring return models)

R81GAA-2:

- vertical board
- terminal board
- 500 ohm resistor
- No. 6-32 x 5/16 in. Phillips-head recessed screw (2)

Tools Needed

- Phillips No. 1 or 2 screwdriver
- 1/8 in. (3 mm) flat-blade screwdriver
- punch and hammer

Precautions and Code Requirements

Observe the following ranges and limitations:

- Do not install the actuator in atmospheres with explosive vapors or escaping gases, or environments where substances corrosive to the device's internal components could be present.
- Seal wiring entering into return air systems to prevent aspiration of corrosive air into the actuator.

Control Input

The actuator is factory set for Direct Acting (DA) for 4 to 20 mA. When in the DA mode, the action of the actuator is Clockwise (CW) with a signal increase. Reverse Acting (RA) is selected by changing the orientation of the jumpers at W1, and the action is Counterclockwise (CCW) with a signal increase. (See Figure 1.) Refer to the *Calibration, Reverse Acting* section before selecting the RA mode.

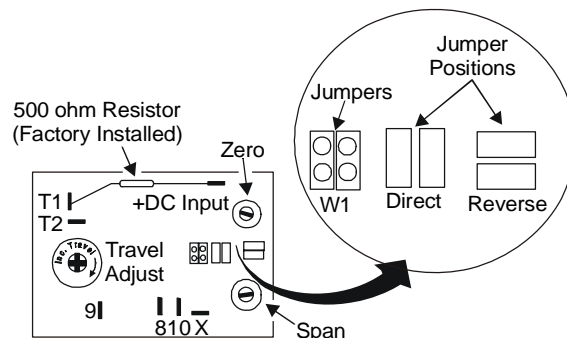

Figure 1: R81GAA-2 Circuit Board

A 500 ohm resistor with quick-connect terminals is factory installed between Terminal T1 and the VDC input terminal for 4 to 20 mA operation.

Note: An optional 750 ohm resistor (RES22A-600) is available for controllers requiring 0 to 24 mA input.

Direction of Rotation

The actuators are factory set at the zero position for 90° travel. The zero position is 10° CW from vertical. (See Figure 2.) Spring return models return CCW to the zero position when power is removed.

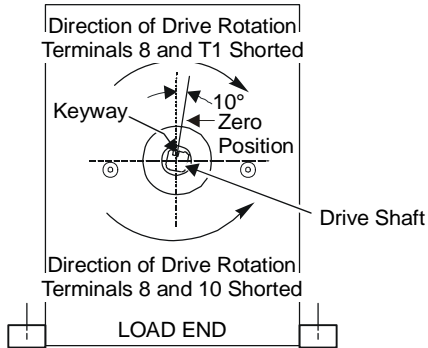

Figure 2: Direction of Rotation

All reference to the direction of rotation is when viewing the load end stamped on the actuator housing as shown in Figure 2. From this view, the CCW limit is the zero position.

Mounting

Actuator

Follow installation steps for the linkage kit used to couple the actuator and the controlled device. When not utilizing a damper or valve linkage kit, use four 1/4 x 1 in. bolts (not included) to mount the actuator.

Upright mounting of the actuator is preferred with the output shaft parallel to the floor. Locate the actuator where the shaft and wiring terminals are accessible.

IMPORTANT: For installations using the CVR83A-600R Weather Cover Kit, mount the actuator in an upright position, so water will not enter the enclosure and damage the actuator.

Make all linkage connections to the drive shaft on the load end of the actuator, rated for up to 200 lb dead weight. Limit the load on the auxiliary end to 10 lb dead weight.

When mounting on a valve, mount the actuator above the horizontal plane of the valve piping to avoid damage to the actuator if the valve leaks or develops condensation.

Note: Valve medium temperatures above 250°F (121°C) are acceptable only if the actuator's maximum ambient temperature is below 105°F (41°C).

R81G Circuit Boards



CAUTION: Equipment Damage Hazard. Disconnect all power supplies before removing the wiring connections and boards to avoid possible damage to the equipment.

Installation

M100X base actuators are provided with no circuit boards. To install a board, loosen the actuator's cover screws, remove the cover, and proceed as follows:

1. Install the terminal board by carefully placing the terminal receptacles onto the pin terminals.
2. Fasten the board with the No. 6-32 x 0.312 Phillips-head recessed screws supplied.
3. Install the vertical board, carefully placing the terminal receptacles onto the two sets of pin terminals so all pins are aligned. (See Figure 3.)

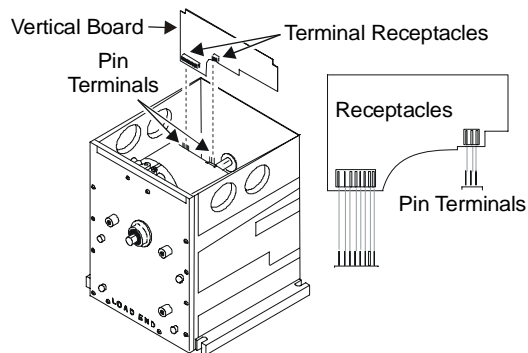

Figure 3: Installing the Vertical Board

- Place the bracket supplied with the actuator over the vertical board, and fasten it with the captive screw. (See Figure 4.)

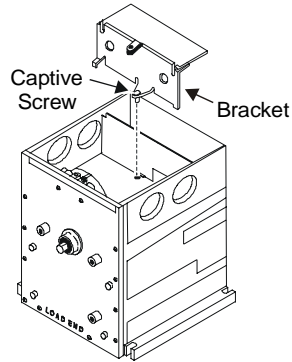
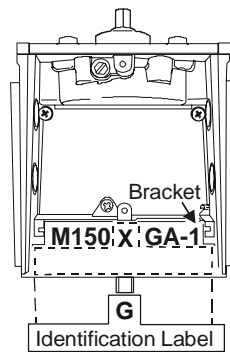

Figure 4: Installing the Bracket

- Apply the adhesive-backed identification label provided to the actuator bracket. (See Figure 5.)



Note: The letter on the label completes the model number of the M100 actuator after R81 installation.

Figure 5: Identification Label

Removal

To remove a circuit board:

- Loosen the two cover screws and remove the actuator cover.
- Disconnect all wiring to the terminal board.
- Loosen the captive screw, and remove the bracket.
- Pull the vertical board straight upward, being careful not to bend or damage the pin terminals.
- Remove the two screws from the terminal board.
- Grasp the receptacles and remove the terminal board by lifting upward, being careful not to bend or damage the pin terminals.

Wiring

CAUTION: **Equipment Damage Hazard.** Disconnect all power supplies before wiring connections are made. Check all wiring connections before applying power to the system. Short-circuited or improperly connected wires will result in permanent damage to the equipment.

- Make all wiring connections using only copper conductors and in accordance with the National Electrical Code and local regulations.
- Use separate transformers on each M100 actuator to avoid potential miswiring or control signal problems.
- Locate all splicing and excess wiring outside the actuator wiring compartment. If desired, add a standard electrical box to the actuator's wiring compartment. (See Figure 6.)

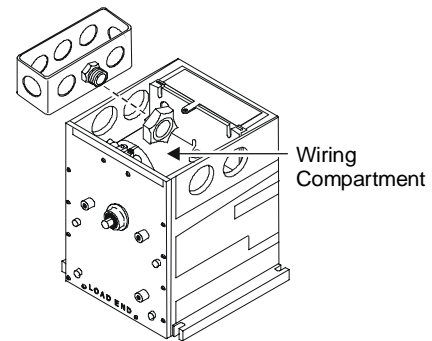

Figure 6: Wiring the Junction Box

The M100G does not require shielded cable on runs less than 50 ft (15 m). Avoid running low voltage control wiring in the same conduit as line voltage or 24 VAC wiring, or other conductors that supply highly inductive loads (contactors, coils, generators, etc.)

Use shielded cable if the control wiring is longer than 50 ft (15 m), located in a common conduit, or near inductive loads. Use 22 AWG, Beldfoil 8761 or an equivalent for runs up to 250 ft (76 m). For runs of 50 to 500 ft (76 to 152 m), use 18 AWG, Beldfoil 8760 or an equivalent. Connect the shield to the controller only.

To connect the wiring:

1. Use a hammer and punch to push the plug out of one of the access holes.
2. Install the conduit connector (not provided) to the actuator, and secure it using the conduit nut provided with the connector.
3. Connect the wiring from the controller to Terminals T1 and +DC Input located in the wiring compartment. (See Figure 7.)

Note: The factory installed resistor must be removed when a DC voltage controller is used.

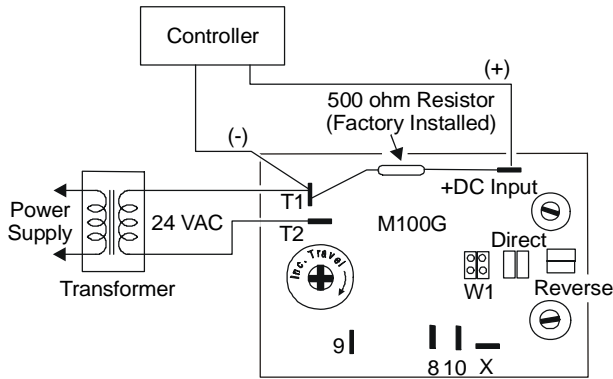

Figure 7: Typical Single Unit Wiring Diagram

Figure 8 shows two M100J actuators being slaved with an M100G in the mA current input mode.

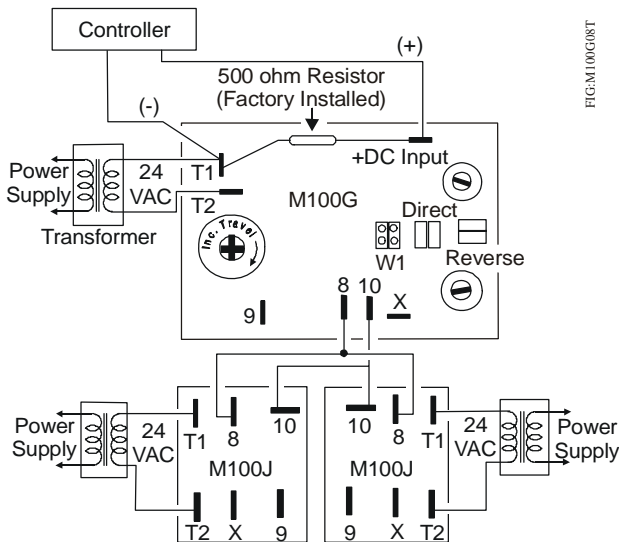

Figure 8: Wiring Diagram for Slaving Actuators

Figure 9 shows an A350P powered by an external transformer driving an M100G actuator with DC voltage input.

Note: When an A350P is used in the voltage output mode, remove the factory installed 500 ohm resistor in the actuator.

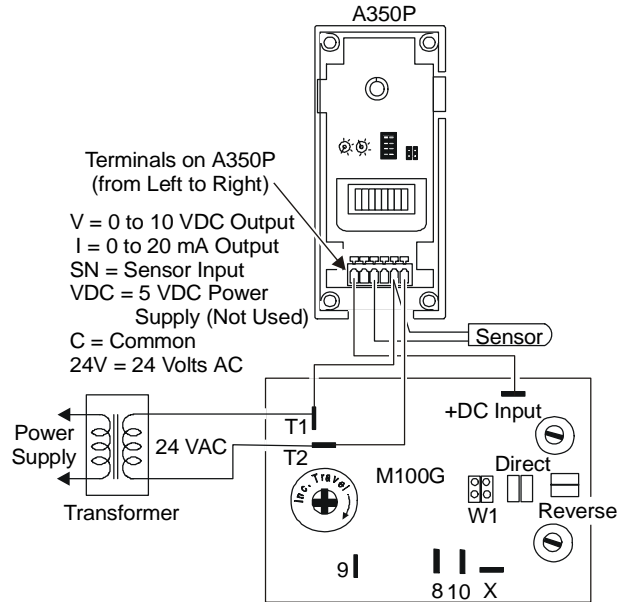

Figure 9: Wiring to an A350P

Figure 10 shows an A350P sequencing two M100G actuators. Set the first actuator's zero to minimum (0.25 VDC). Set the span to the desired portion of the A350P output signal that will drive the actuator from full CCW to full CW, for example, for 5 VDC.

Set the second actuator's zero to the A350P voltage output where actuation begins, for example, 5.5 VDC. Set the span to the desired portion of the A350P output signal that will drive the actuator from full CCW to full CW, for example, 9.5 VDC.

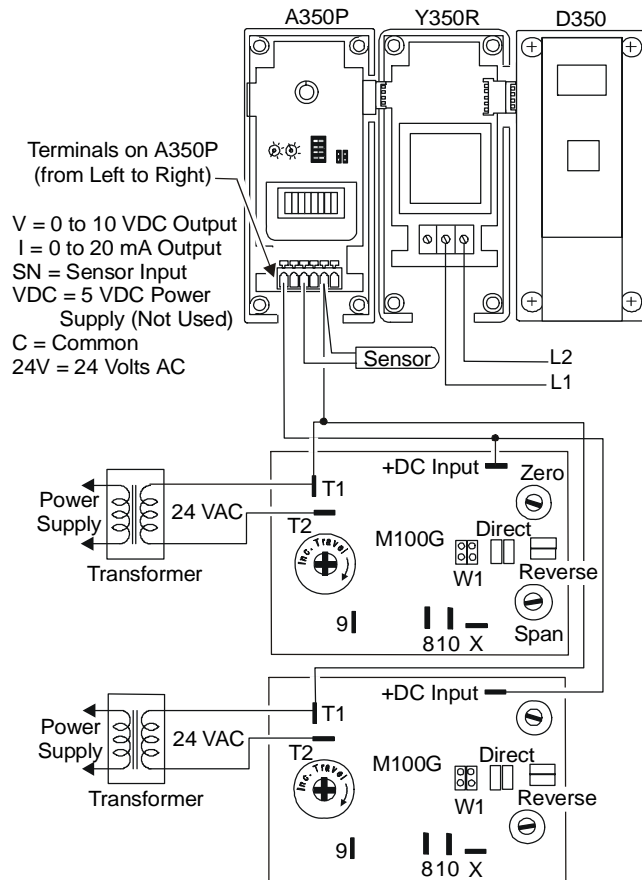

Figure 10: Sequencing with the A350P

Figure 11 shows an M100G wired to a TC-6100 Cybertronic temperature controller. Use Connections 1 and 13 on the TC-6100.

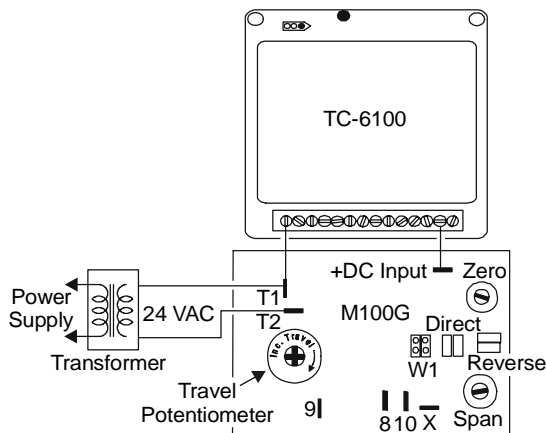

Figure 11: Wiring to a TC-6100 Controller

To connect the wires for all applications:

1. Loosen the two screws securing the top cover, and remove the top cover for access to the wiring terminals.
2. Use a hammer and punch to push out one of the access hole plugs.
3. Install the conduit connector to the actuator, and secure it using the conduit nut provided with the connector.
4. Connect the controller to the terminals located in the wiring compartment.
5. Connect 24 VAC to Terminals T1 and T2.

Note: For more information on any of the controllers, refer to the applicable controller literature.

Calibration

Travel

Travel is field adjustable from 65 to 270° by turning the travel potentiometer. (See Figure 7.) Changing the travel adjustment affects the CW limit of the actuator's rotation.

1. Supply 24 VAC to Terminals T1 and T2, and drive the actuator to its CW limit by jumpering Terminals 8 and T1.
2. Turn the travel potentiometer CW to increase the travel, and then CCW to reduce the total travel.

Note: Refer to the appropriate damper or valve linkage literature for more information on travel adjustment.

Zero and Span

The zero (0.25 minimum, 24 VDC maximum) and span (2 minimum, 18 VDC maximum) are field adjustable. This allows the selection of any portion of the control input signal to fully modulate the actuator.

Direct Acting

Set the actuator for the desired input, and refer to Figure 7.

Note: Use a factory installed 500 ohm resistor between T1 and +DC Input for a 0 to 20 mA input signal. Use a field supplied 750 ohm resistor for 0 to 24 mA. Do not use a resistor for VDC voltage input.

1. Set the jumpers to the DA position as shown in Figure 1.
2. Apply 24 VAC to Terminals T1 and T2.

3. Increase the zero to its maximum, and decrease the span to its minimum.

Note: Direction indicators for increasing zero and span adjustments are on the potentiometer.

4. Apply power to the controller supplying the VDC/mA input signal to the actuator.
5. Using a DC voltmeter, adjust the controller setpoint to produce the minimum voltage at which the actuator will be at the desired full CCW position.

Note: The actuator ignores voltages below the selected value.

6. Slowly decrease the zero until the actuator begins to respond. The actuator should start and run CW approximately two degrees.
7. Slowly increase the zero enough to return the actuator to its normal CCW position.
8. Leave the zero set at this point.
9. Adjust the controller setpoint to produce the maximum voltage at which the actuator will be at the desired full CW position.
10. Slowly increase the span until there is slight CCW movement of the actuator. The actuator should start and back up approximately two degrees.
11. Decrease the span just enough to return the actuator to its maximum CW travel limit, ensuring complete actuator travel.
12. Leave the span set at this point.
13. Repeat the preceding steps to verify achievement of the complete control range. Perform at least three complete operating cycles of the system before leaving the installation.

Reverse Acting

To change the actuator to RA, proceed as follows:

Note: Use a factory installed 500 ohm resistor between T1 and +DC Input for a 0 to 20 mA input signal. Use a field supplied 750 ohm resistor for 0 to 24 mA. Do not use a resistor for VDC voltage input.

1. Set the jumpers to the RA mode as shown in Figure 1.
2. Apply 24 VAC to Terminals T1 and T2, and wait for the actuator to travel to its full CW limit.
3. Decrease the zero and span to their minimum positions.

Note: Direction indicators for increasing zero and span adjustments are on the potentiometer.

4. Apply power to the controller supplying the VDC/mA input signal to the actuator.

5. Using a voltmeter, adjust the controller setpoint to the maximum voltage at which the actuator will be at the desired full CCW position.

Note: The actuator ignores voltages above the selected value.

6. Slowly increase the zero until the actuator begins to respond. The actuator should start and run CW approximately two degrees.
7. Slowly decrease the zero enough to return the actuator to its normal CCW position.
8. Leave the zero set at this point.
9. Adjust the controller setpoint to the minimum voltage at which the actuator is at the desired full CW position.

Note: The actuator ignores voltages below the selected value.

10. Repeat Steps 10 to 13 in the *Direct Acting* section.

Manual Override



CAUTION: Equipment Damage Hazard.
This procedure is for checking the actuator only, and not for continuous operation. Make sure overriding the actuator does not damage the system or the actuator's components.

Proceed as follows to manually override the actuator:

1. Disconnect all control inputs before manually overriding the actuator.
2. Connect Terminals 8 and T1 to drive the actuator CW. This overrides the VDC/mA input, and drives the motor to its full adjusted travel.
3. Connect Terminals 8 and 10 to drive the actuator CCW. This overrides the VDC/mA input, and drives the motor to its starting point.

Checkout Procedure

Once installation and wiring are complete, and the actuator and linkage are assembled to the valve or damper:

1. Make system settings, apply power, and use the controller to cycle the actuator.
2. Observe at least three complete operating cycles, to ensure all components are functioning correctly.

IMPORTANT: Do not stall the actuator using the damper or valve. If the actuator is not allowed to complete its full stroke, damage may result.

Troubleshooting

To troubleshoot the M100G, proceed as follows:

1. Remove the control signal.
2. Maintain isolated 24 VAC power.
3. Jumper Terminal 8 to T1 to drive the actuator CW.
4. Jumper Terminal 8 to 10 to drive the actuator CCW.

Using a voltmeter, proceed as follows to ensure proper functioning of the actuator and associated controls:

1. Make sure the actuator model selected has a range that covers the controller voltages desired.
2. Make sure the voltage at Terminal 8 (with reference to Terminal T1) is approximately +12 VDC.
3. Adjust the controller setpoint up and down to ensure the voltage received by the actuator results in proportional changes in the output voltage across Terminals 8 and 10. Output voltage must be between 0 and -2 VDC (with reference to Terminal 10).

See Table 1 for accessories and Table 2 for product specifications.

Table 1: Accessories

Product Code	Description
Y68AA-1	Transformer, 120/24 VAC, 40 VA, 60 Hz, Class 2
Y68DA-1	Transformer, 240/24 VAC, 40 VA, 60 Hz, Class 2
Y68HA-1	Transformer, 24/24 VAC, 40 VA, 60 Hz, Class 2
S91DJ-1	Auxiliary switch kit with one Single-Pole, Double-Throw (SPDT) switch
S91EJ-1	Auxiliary switch kit with two SPDT switches
S91PT-1	Auxiliary potentiometer kit, 1000 ohm, 1/3 watt
CVR83A-600R	Weather cover kit
Y20DAA-2	Mounts actuator to top of duct or any flat surface; includes LVR27A-602, LVR27A-600, ROD16-3, and SWL10A-603Y (2)
Y20DAB-2	Mounts the actuator to the side of a duct or wall; includes all items in the Y20DAA-2 plus one BKT22A-602
Y20EBA-1	Valve linkage kit for mounting Honeywell® valves with 1/4-28 stem connection to M120 or M130 actuators
Y20EBA-2	Valve linkage kit for mounting Honeywell valves with 1/4-28 stem connection to M150 actuators
Y20EBA-3	Valve linkage kit for mounting Barber-Coleman® valves with 1/4-28 stem connection to M120 or M130 actuators
Y20EBA-4	Valve linkage kit for mounting Barber-Coleman valves with 1/4-28 stem connection to M150 actuators
Y20EBD-1	Linkage kit for M120 or M130 actuators and 1-1/4 in. (DN 32) valves, produces 75 lb (334 N) seating force
Y20EBD-2	Linkage kit for M140 actuators and 1-1/4 in. (DN 32) valves, produces 150 lb (607 N) seating force
Y20EBD-3	Linkage kit for M150 actuators and 1-1/4 in. (DN 32) valves, produces 270 lb (1202 N) seating force
Y20EBD-5	Linkage kit for M110 actuators and 1-1/4 in. (DN 32) valves, produces 40 lb (178 N) seating force
Y20EBD-6	Linkage kit for M120 or M130 actuators and 1-1/4 in. (DN 32) valves, produces 100 lb (449 N) seating force
Y20EBE-1	Coupling adaptor to convert valves with a 5/16 in. stem and a hold down nut for Johnson Controls® 1/2 to 3 in. valves manufactured prior to March 1969
Y20EBE-2	Stem adaptor and centerpiece collar to adapt VT Series valves with slotted stems (Y20EBD-5 kit also required)
Y20EBE-3	Hold down nut for cast iron and VB Series 2-1/2 to 4 in. valves, yoke nut for Barber-Coleman 1/2 to 2 in. valves
Y20EBE-4	Stem connector for Barber-Coleman 2-1/2 to 4 in. valves (5 per package) used with Y20EBD-3 or Y20EBD-6
Y20EBE-11	Valve linkage adaptor kit for VG7000 valves (Y20EBD Series kit also required)
VG7000-M110	Mounting kit for M110 actuator and 1/2 through 2 in. (DN15 through DN50) valves
VG7000-M130	Mounting kit for M130 actuator and 1/2 through 2 in. (DN15 through DN50) valves
VG7000-M140	Mounting kit for M140 actuator and 1/2 through 2 in. (DN15 through DN50) valves
VG7000-M150	Mounting kit for M150 actuator and 1/2 through 2 in. (DN15 through DN50) valves
Y20DFC-1	Damper linkage kit for mounting the actuator to the inside or outside frame of CD-1300 dampers only

Table 2: Specifications

Product	M100G Series Proportional Actuator with VDC/mA Control Signal Input R81GAA-2 Interface Board	
Power Requirements	24 VAC, Class 2 (20 to 30 VAC) at 50/60 Hz, 25 VA spring return, 20 VA non-spring return	
Input Signal	0 to 24 VDC, 0 to 20 mA with 500 ohm resistor; factory calibrated 4.0 to 19.6 mA	
Input Signal Adjustments	Direct Acting (DA) or Reverse Acting (RA) operation Zero: Adjustable 0.25 to 24 VDC Span: Adjustable 2.00 to 18 VDC	
Mechanical Connection	3/8 in. (9.5 mm) square shaft, both ends Maximum dead weight on output shaft: 200 lb (91 kg), load end; 10 lb (4.5 kg), auxiliary end	
Mechanical Output	Running Torque	Breakaway and Stall (minimum)
	M110 25 lb-in (2.8 N-m) spring return	100 lb-in (11 N-m)
	M120 35 lb-in (4.0 N-m)	70 lb-in (7.9 N-m)
	M130 50 lb-in (5.6 N-m) spring return	200 lb-in (23 N-m)
	M140 75 lb-in (8.5 N-m)	150 lb-in (17 N-m)
	M150 150 lb-in (17 N-m)	300 lb-in (34 N-m)
Rotation Range	Fixed zero, adjustable full travel 65 to 270°; factory set at 90° full travel	
Input Impedance	44,000 ohms	
Rotation Timing (at Rated Load)	60 seconds for 160° travel nominal, 60 Hz 38 seconds for 90° travel nominal, 60 Hz 75 seconds for 90° spring return	
Cycle Life	M110 and M130 spring return models: 150,000 cycles at rated load M120, M140, and M150 non-spring return models: 200,000 cycles at rated load	
Electrical Connection	1/4 in. quick-connect spade terminals	
Action	CW rotation on increasing signal (DA), CCW rotation on increasing signal (RA); factory set for DA	
Ambient Operating Conditions	Spring Return: -35 to 125°F (-37 to 52°C), 90% RH Non-spring Return: -40 to 125°F (-40 to 52°C), 90% RH	
Ambient Storage Conditions	-40 to 140°F (-40 to 60°C), 90% RH	
Dimensions (H x W x D)	Spring Return: 5.81 x 5.64 x 7.68 in. (148 x 143 x 195 mm) Non-spring Return: 5.81 x 5.64 x 4.94 in. (148 x 143 x 125mm)	
Shipping Weight	Spring Return: 9 lb (4.1 kg) Non-spring Return: 6.5 (2.9 kg)	
Enclosure	NEMA 2, IP32	
Agency Compliance	M1x0GGA is UL Recognized, File E27734, CCN XAPX2 M1x0GGA is UL Listed, File E107041, CCN PAZX CSA Certified, File LR948, Class 4813 02	
EU Directive Compliance	89/336/EEC (CE Mark), M1x0GGA models only	

The performance specifications are nominal and conform to acceptable industry standards. For application at conditions beyond these specifications, consult the local Johnson Controls office. Johnson Controls, Inc. shall not be liable for damages resulting from misapplication or misuse of its products.



Controls Group
507 E. Michigan Street
P.O. Box 423
Milwaukee, WI 53202

Printed in U.S.A.
www.johnsoncontrols.com