

VA-7450 Series Electric Valve Actuators

Applications

VA-7450 Series Electric Valve Actuators provide on/off, floating, or proportional control in Heating, Ventilating, and Air Conditioning (HVAC) applications. The compact design of this actuator series makes it ideal for installations in confined locations, such as fan coil applications. The VA-7450 Series Actuators are designed for easy mounting in the field, or they can be ordered factory coupled to Johnson Controls® VG4000 or VG5000 Series Zone Valves.

IMPORTANT: Before specifying the VA-7450 Series Electric Valve Actuator for plenum applications, verify acceptance of exposed plastic materials in plenum areas with the local building authority. Building codes for plenum requirements vary by location. Some local building authorities accept compliance to UL 1995, Heating and Cooling Equipment, while others use different acceptance criteria.

IMPORTANT: Use this VA-7450 Series Electric Valve Actuator only to control equipment under normal operating conditions. Where failure or malfunction of the VA-7450 Series could lead to personal injury or property damage to the controlled equipment or other property, additional precautions must be designed into the system. Incorporate and maintain other devices such as supervisory or alarm systems or safety or limit controls intended to warn of, or protect against, failure or malfunction of the VA-7450 Series.

Installation

Parts Included

- VA-7450 Series Electric Valve Actuator with coupler
- three spare jumpers (VA-7452-90011 only)

Dimensions

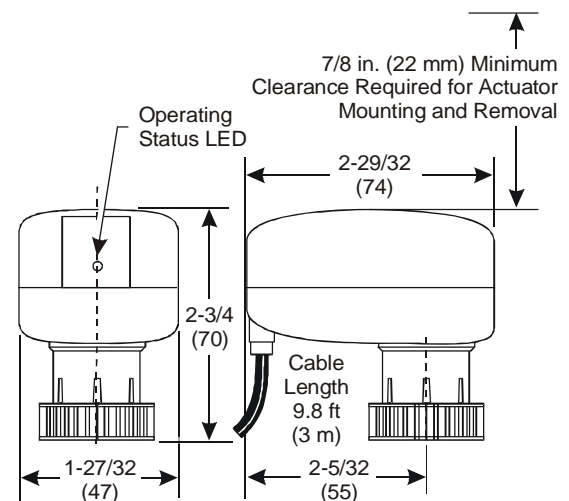

Figure 1: VA-7450 Series Electric Valve Actuator Dimensions, in. (mm)

Accessories

A VA-7450-8900 Manual Override Ring is available (ordered separately) to manually open two-way Normally Closed (N.C.) or the N.C. port of three-way mixing VG4000 or VG5000 Series Zone Valves (as illustrated in Figure 2). The VA-7450-8900 is assembled between the VG4000 or VG5000 Series valve body and the VA-7450 Series Electric Valve Actuator.

Note: The VA-7450-8900 Manual Override Ring does not fully close two-way Normally Open (N.O.) or the N.O. port of three-way mixing VG4000 or VG5000 Series Zone Valves.

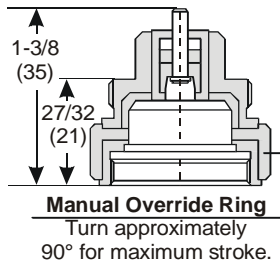

Figure 2: VA-7450-8900 Manual Override Ring Dimensions, in. (mm)

VA-7450-10011 (On/Off or Floating Control)

Use the VA-7450-8900 Manual Override Ring for two-way N.C. or the N.C. port of three-way mixing VG4000 and VG5000 Series Zone Valves.

VA-7452-90011 (Proportional Control)

Use the VA-7450-8900 Manual Override Ring if a 24 VAC power supply is not available.

If a 24 VAC power supply is available with no controller signal, set the action of Jumper 5 (JP5) to Direct Acting (DA) to drive the actuator to the fully up position, or Reverse Acting (RA) to drive the actuator to the fully down position. See Table 1 for more details.

Mounting

All VA-7450 Series Electric Valve Actuators ship from the factory in the fully up position. Before mounting the actuator, please note the following:

- Do not remove the mounting instruction tag that is attached to the actuator body.
- If the actuator was powered prior to mounting it on the valve, be certain to return the actuator to its original fully up position before proceeding further.
- Check that the actuator is free of thermal insulating material.
- Allow a minimum clearance of 7/8 in. (22 mm) above the actuator body, as illustrated in Figure 1.
- Do not use the actuator as a lever to thread the valve body onto the piping.

IMPORTANT: Mount the actuator within 90° of the vertical position above the valve body. Failure to mount the actuator within 90° may permit water or moisture to travel down the valve stem, damaging the actuator and voiding the warranty.

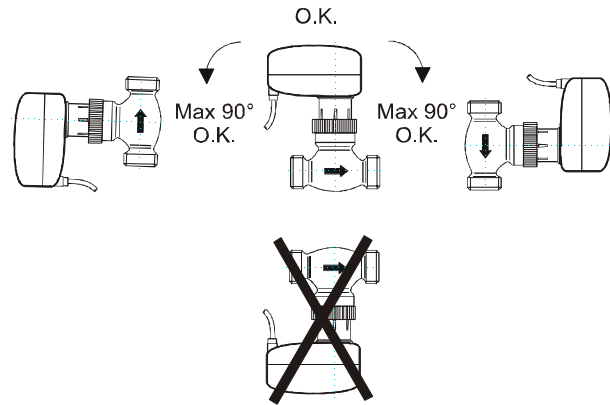

Figure 3: Proper Actuator and Valve Assembly Orientation

To mount the VA-7450 Series Electric Valve Actuator onto a VG4000 or VG5000 Series Zone Valve, see Figure 4 and proceed as follows:

1. Pipe the VG4000 or VG5000 Series Zone Valve into the system.
2. Check that the VA-7450 Series Electric Valve Actuator is in the fully up position.
3. Place the threaded coupler of the actuator over the valve stem and bonnet.
4. Rotate the actuator body to the desired mounting position.
5. Hand tighten the threaded coupler to secure the actuator to the valve body.

IMPORTANT: Do not use a wrench or the body of the VA-7450 Series Electric Valve Actuator to tighten the threaded coupler. Tightening the threaded coupler in this manner may damage the actuator. If the actuator needs to be repositioned after initial installation, loosen the threaded coupler, rotate the actuator body to the desired mounting position, and hand tighten the threaded coupler to secure the actuator to the valve body.

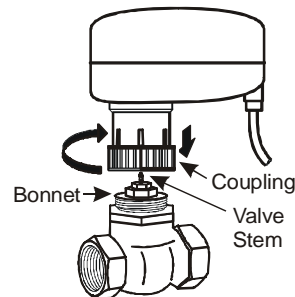

Figure 4: Mounting the VA-7450 Series Electric Actuator onto a VG4000 or VG5000 Series Valve Body

Wiring

To wire the VA-7450 Series Electric Valve Actuator, see the appropriate wiring diagram in Figure 5.

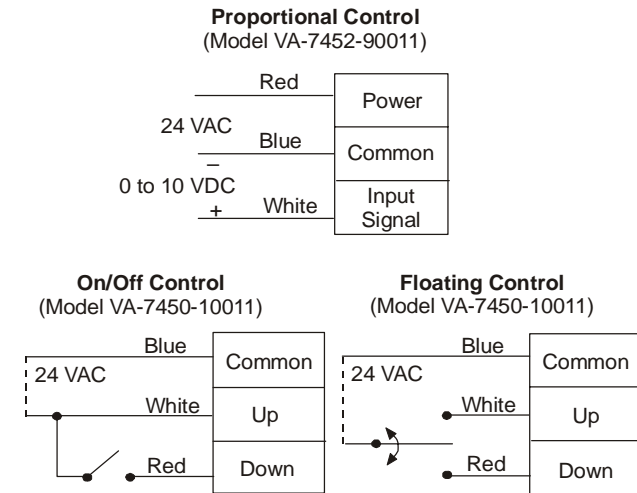

Figure 5: Wiring the VA-7450 Series Electric Valve Actuator

CAUTION: Risk of Property Damage.
Do not apply power to the system before checking all wiring connections. Short circuited or improperly connected wires may result in permanent damage to the equipment.

IMPORTANT: Make all wiring connections in accordance with local, national, and regional regulations. Do not exceed the electrical ratings of the VA-7450 Series Electric Valve Actuator.

Setup and Adjustments

Jumper Settings (VA-7452-90011 Only)

To set the jumpers on the VA-7452-90011, proceed as follows:

- Carefully remove the jumper access door using the tip of a 1/8 in. (3 mm) blade screwdriver, as illustrated in Figure 6.

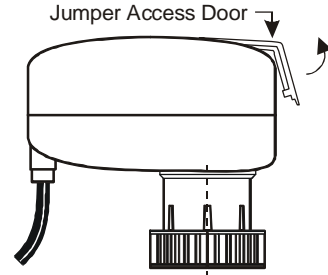

Figure 6: Opening the Jumper Access Door

- See Table 1 for the various jumper settings.

Table 1: Jumper Settings

Jumper	Jumper Function		Factory Setting
	Jumper IN	Jumper OUT	
1	Anti-Sticking Cycle On	Off	Off
2	Input Signal Range (VDC) 0 to 10	5 to 10	0 to 10
3	0 to 5	0 to 5	
4	Valve Body Type Three-Way	Two-Way	Two-Way
5	Action Direct (DA)	Reverse (RA)	DA
6	Valve Normal Position PDTO (N.C.)	PDTC (N.O.)	PDTC

- Remove or add jumpers using a small needle-nose pliers. Figure 7 illustrates jumper locations and factory settings.

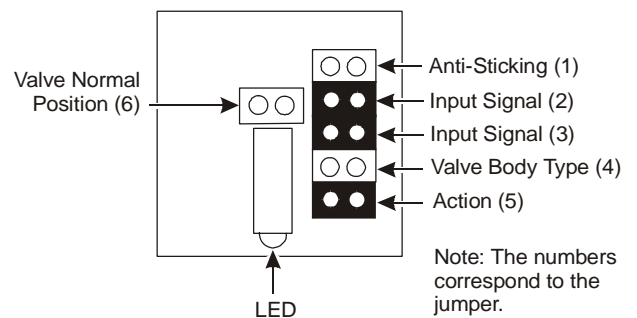





Figure 7: Jumper Locations and Factory Settings

- Reinstall the jumper access door (top edge first) and press firmly on the front of the door until it snaps in place.

Operation

To ensure good system performance, use a Proportional plus Integral (PI) controller. All VA-7450 Series Electric Valve Actuators feature a Light-Emitting Diode (LED) display designed to provide direct, visual indication of the actuator operating status. See Table 2 for an explanation of the LED display.

Table 2: Actuator Operating Status

LED Display	Description
On 	Power Line Present; Motor Not Running
Single Flash 	Motor Running
Double Flash 	End-of-Stroke Confirmation Cycle or Anti-Sticking Cycle
Off 	Power Line Not Present

On/Off or Floating Control (VA-7450-10011)

When the input signal is applied to the **Common** and **Down** wires, the actuator motor drives the gear assembly and pushes down on the valve stem, against the force of the valve return spring. When the input signal is removed, the actuator remains in its current position.

When the input signal is applied to the **Common** and **Up** wires, the actuator retracts, allowing the valve return spring to move the valve stem up in the direction of its normal position. When the input signal is removed, the actuator remains in its current position.

If a continuous input signal is applied to the **Down** or **Up** wire, the actuator motor shuts off after approximately 80 seconds.

End-of-Stroke Confirmation: When the input signal is applied continuously in the same direction, the actuator turns on every 2 hours and drives the motor in the signal direction for approximately 80 seconds. This action confirms the end-of-stroke position.

Note: Johnson Controls Application Specific Controllers (ASCs) do not continuously power the floating outputs of VA-7450 Series Electric Valve Actuators. For more information, refer to the appropriate ASC product literature.

Proportional Control (VA-7452-90011)

When the input signal increases in Direct Acting (DA) configuration or decreases in Reverse Acting (RA) configuration, the actuator motor drives the gear assembly and pushes down on the valve stem, against the force of the valve return spring.

When the input signal decreases in DA configuration or increases in RA configuration, the actuator retracts, allowing the valve return spring to move the valve stem up in the direction of its normal position.

End-of-Stroke Confirmation: When the input signal is applied 0 or 100% continuously, the actuator turns on every 2 hours and drives the motor in the signal direction for approximately 80 seconds. This action confirms the end-of-stroke position.

Auto-Commissioning: When power is applied to the actuator, the actuator self-calibrates to the full-stroke end position by performing a complete cycle. The actuator motor drives in the stem down direction for approximately 80 seconds, then it drives to the input signal command position.

Anti-Sticking Cycle: When the anti-sticking cycle is enabled (On), the actuator performs one complete cycle every 24 hours to clear possible accumulations of impurities from the valve plug and seat. The anti-sticking cycle feature is jumper selectable.

Note: It is not possible to control the timing of the anti-sticking cycle. Do not select this feature if unscheduled cycling of the valve is undesirable for the application. The actuator does not respond to an input signal command while it is performing an end-of-stroke confirmation, auto-commissioning, or an anti-sticking cycle; however, the actuator drives to the commanded position once the cycle is complete.

Valve Selection: The actuator is factory set for use with two-way N.O., Push-Down-to-Close (PDTC) VG4000 and VG5000 Series Zone Valves. For two-way N.C., Push-Down-to-Open (PDTO) VG4000 and VG5000 Series applications, change the valve normal position jumper to PDTO. For three-way mixing VG4000 and VG5000 Series applications, set the valve body type jumper to three-way and set the valve normal position jumper so that it corresponds to the service port of the valve. See Figure 8 for more details.

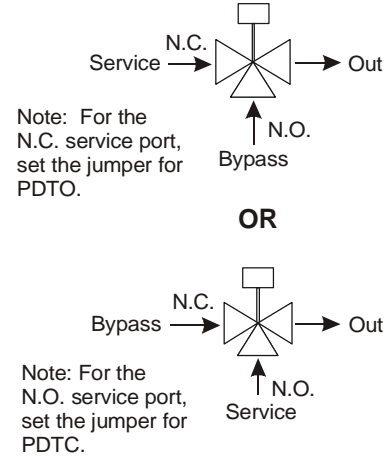

Figure 8: Setting the Valve Normal Position Jumper

Technical Specifications

Product	VA-7450 Series Electric Valve Actuators	
Power Requirements	24 VAC \pm 15% at 50/60 Hz; 2.7 VA at Maximum Power Supply; Class 2	
Input Signal	VA-7450-10011	24 VAC, 50/60 Hz
	VA-7452-90011	0 to 10 VDC
Input Signal Adjustments	VA-7450-10011	None
	VA-7452-90011	Input Signal: 0 to 10 VDC, 0 to 5 VDC, or 5 to 10 VDC
		Direction: Direct (Drive Down) or Reverse (Drive Up) with Input Signal Increase
		Valve Type: Two-Way N.O. (PDTC), Two-Way N.C. (PDTO), or Three-Way Mixing
Input Impedance	VA-7450-10011	3,900 ohms
	VA-7452-90011	80,000 ohms
Electrical Connections	22 AWG Cable; 9.8 ft (3 m) Long	
Mechanical Connections	Threaded Coupling for Johnson Controls VG4000 or VG5000 Series Zone Valves	
Enclosure	Glass and Mineral-Filled Plastic Resin; NEMA 1, IP40 (EN 60529)	
Output Force	21.5 lb (96 N) Minimum	
Stroke	0.20 in. (5 mm) Maximum	
Full Stroke Cycle Time	65 Seconds	
Full Stroke Cycles	100,000	
Audible Noise Rating	25 dBA Maximum at 3.3 ft (1 m)	
Fluid Temperature Limits	35 to 203°F (2 to 95°C)	
Ambient Operating Conditions	32 to 122°F (0 to 50°C), Noncondensing	
Ambient Storage Conditions	-4 to 149°F (-20 to 65°C), Noncondensing	
Standards Compliance	United States	UL 873 Listed, File E27734, CCN XAPX Actuator Housing is Plenum Rated per UL 1995, Heating and Cooling Equipment
	Canada	CSA C22.2 No. 139 Certified, File LR85083, Class 3221 01
CE Mark	Per EMC Directive (89/336/EEC)	
Shipping Weight	0.40 lb (0.18 kg)	

The performance specifications are nominal and conform to acceptable industry standards. For application at conditions beyond these specifications, consult the local Johnson Controls office. Johnson Controls, Inc. shall not be liable for damages resulting from misapplication or misuse of its products.



Controls Group
507 E. Michigan Street
P.O. Box 423
Milwaukee, WI 53201

Published in U.S.A.
www.johnsoncontrols.com