

VSD Series Quick Reference Guide



IMPORTANT: This guide is intended to provide a quick reference to the VSD Series drive's Application Software features for start-up, programming and service. It does not replace the need to thoroughly read and understand the User Manual.

Shipped from the factory the VSD Series drive has six Ready Applications, with the drive default set to Remote Application.

Applications:

- **Remote Input** used for Remote Frequency Contact without PI
- **Duct Static** used to control fans with pressure transducer and provide WC/PA units to keypad
- **Building Static** used to control fans with pressure transducer and provide WC/PA units to keypad
- **Pressure PSI** used to control pumps or fans with pressure transducer and provide PSI/kPa units to keypad
- **Temperature °F, °C** used to control pumps or fans with pressure transducer and provide °F/°C units to keypad
- **Generic PI** used to control pumps or fans with a pressure transducer

Inspection

General

Upon receipt of the unit, verify that the catalog number and unit options stated on the shipping container match those stated on the order/purchase form.

Inspect the equipment upon delivery. Report any carton damage to the carrier prior to accepting the delivery. Have this information noted on the freight bill. Johnson Controls is not responsible for damage incurred in shipping.

Unpacking

Remove all packing material from the unit. Be sure to remove all packing material from lug location. Also, make sure no packing material is left behind that would block the airflow to the fan.

Check the unit for any signs of shipping damage. If damage to the product is found after unpacking, report it to the freight company. Retain the packing materials for the carrier to review.

Verify that the unit's catalog number and options match those stated on the order/purchase form.

Storage

It is recommended that the unit be stored in its original shipping box/crate until it is to be installed.

The unit should be stored in a location where:

- The ambient temperature is between -58°F and 158°F (-50°C and 70°C)
- The relative humidity is between 0% and 95%, non-condensing
- The environment is dry, clean, and non-corrosive
- The unit will not be subjected to high shock or vibration conditions

Power Wiring — Open Chassis Drives and Enclosed Drives

FR: 7, 8, 9

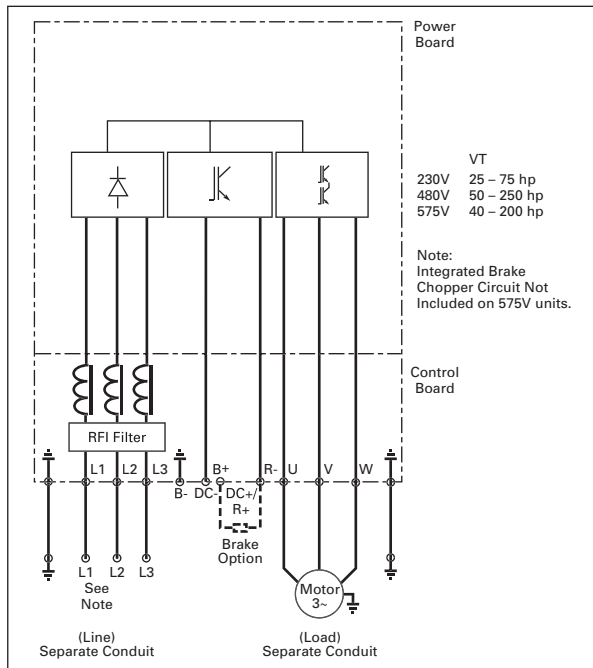

Figure 1: Power and Motor Wiring Diagram for Large hp Drives

FR: 4, 5, 6

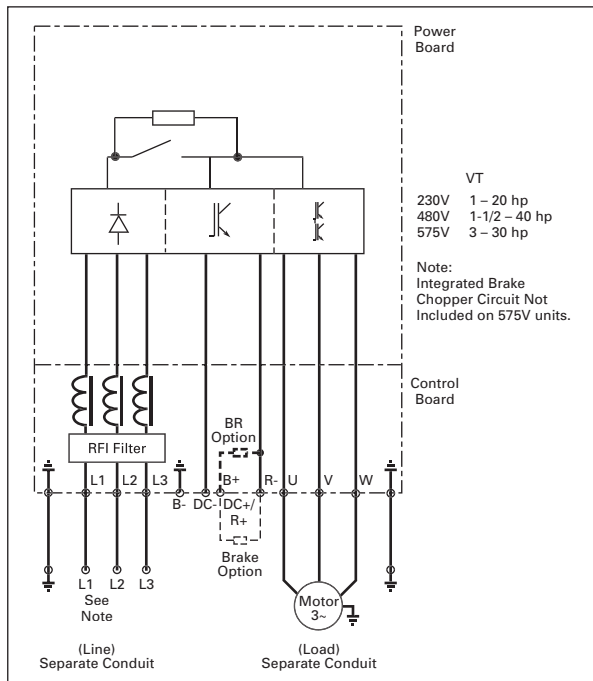

Figure 2: Power and Motor Wiring Diagram for Small hp Drives

Control Wiring

General Information

The control unit of the VSD Series drive consists of the control board and various option boards that plug into the five slot connectors (A to E) of the control board.

Galvanic isolation of the control terminals is provided as follows:

- Control connections are isolated from power, and the GND terminals are permanently connected to ground.
- Digital inputs are galvanically isolated from the I/O ground.
- Relay outputs are double-isolated from each other at 300V AC.

Option Board General Information

The VSD Series drives can accommodate a wide selection of *expander* and *adapter boards* to customize the drive for your application needs.

The drive's control unit is designed to accept a total of five option boards. Option boards are available for normal analog and digital inputs and outputs, for communication and for additional application-specific hardware.

The VSD Series factory installed standard option board configuration includes an A9 I/O board and an A2 relay output board, which are installed in slots A and B. For information on additional option boards, see the VSD Series drives option board manuals.

Note: If your VSD Series drive has been shipped with a factory installed IntelliPass bypass, the B5 option board is installed in slot C.

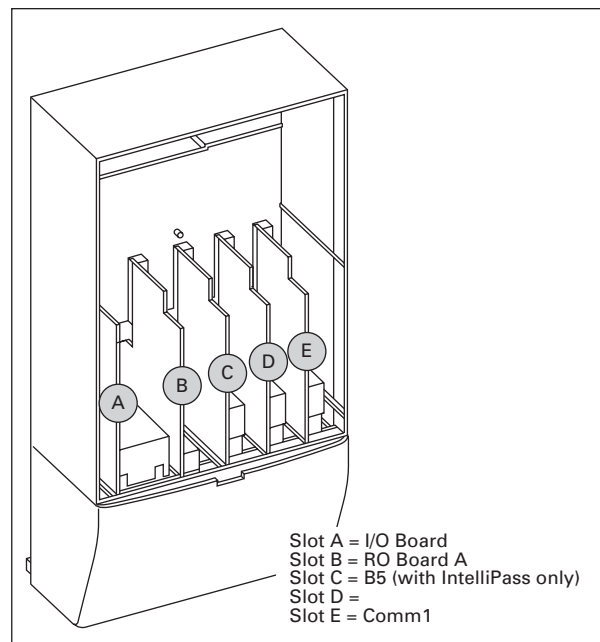

Figure 3: Option Board Slots

Main Control Board Wiring Default in Slot A and B

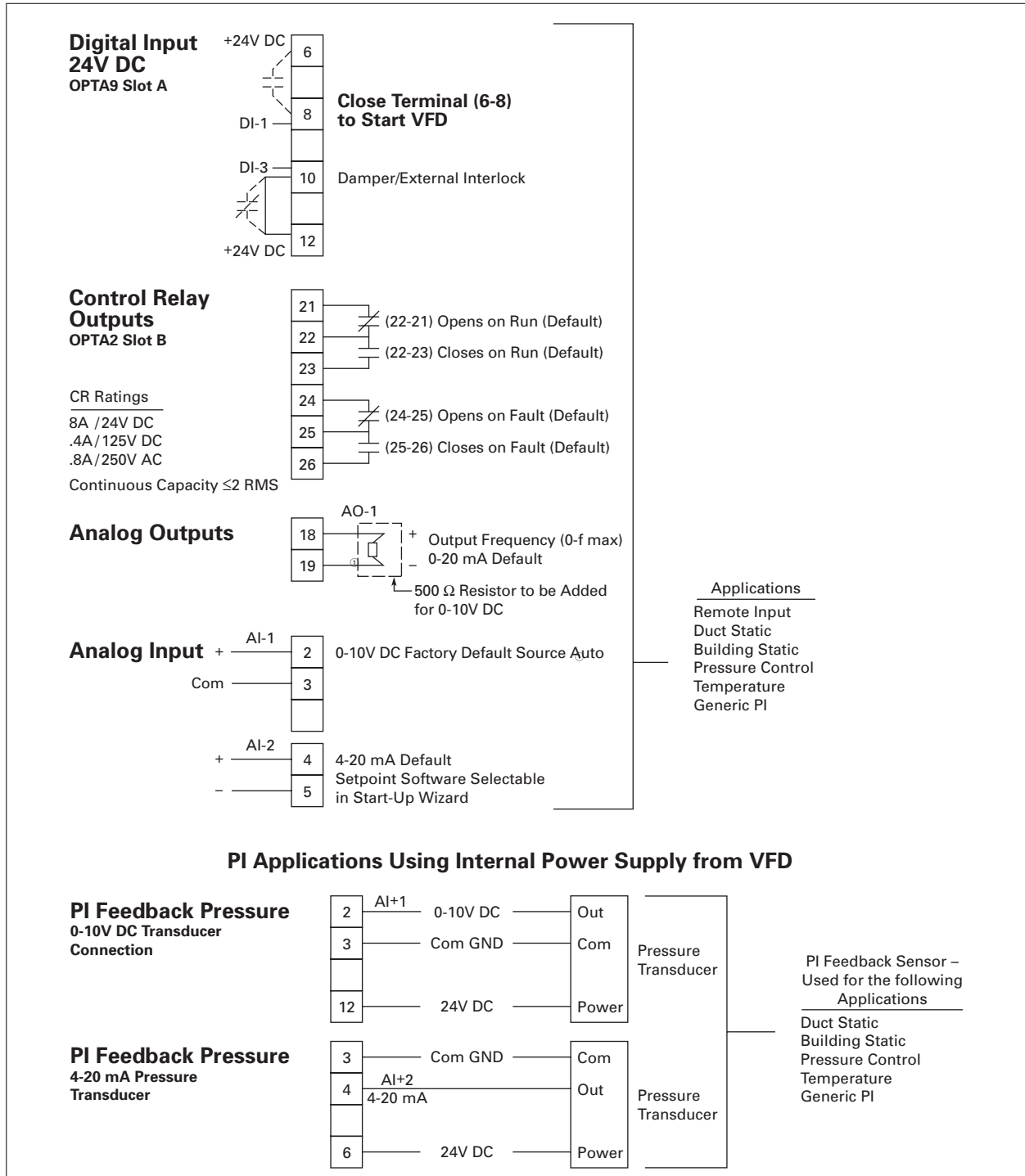

Figure 4: Wiring Diagrams (Default)

① Card is programmable for a 0 – 10V DC with change in jumper. Add X6 jumper on Board A6 from A-B to C-D.

Start-Up Wizard — Duct Static, Building Static, Pressure Control, Temperature, Generic PI

Upon initial power up, the **Start-Up Wizard** guides the commissioner through the basic VSD Series setup. The **Start-Up Wizard** may be set to function upon power up by setting parameter P5.5.3, or by pressing the STOP button for 5 seconds while in the "Operate Menu". The display will read "Startup Wizard" ACTIVATED after 5 seconds.

Note: Use \uparrow / \downarrow for changing parameter. Then press ENTER to save and move forward.

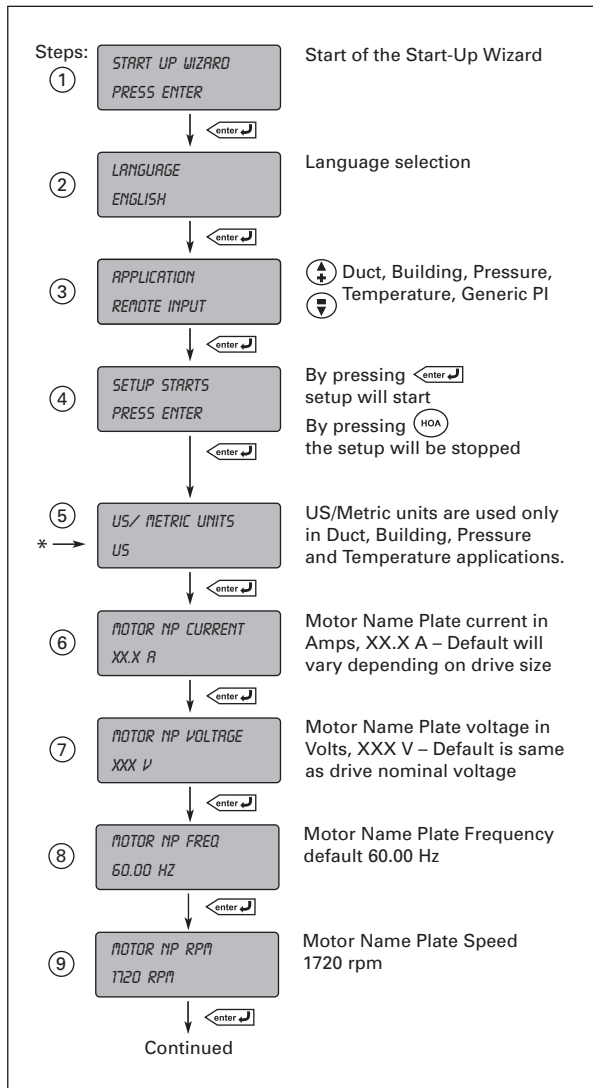

Figure 5: Start-Up Wizard Navigation (1 of 3)

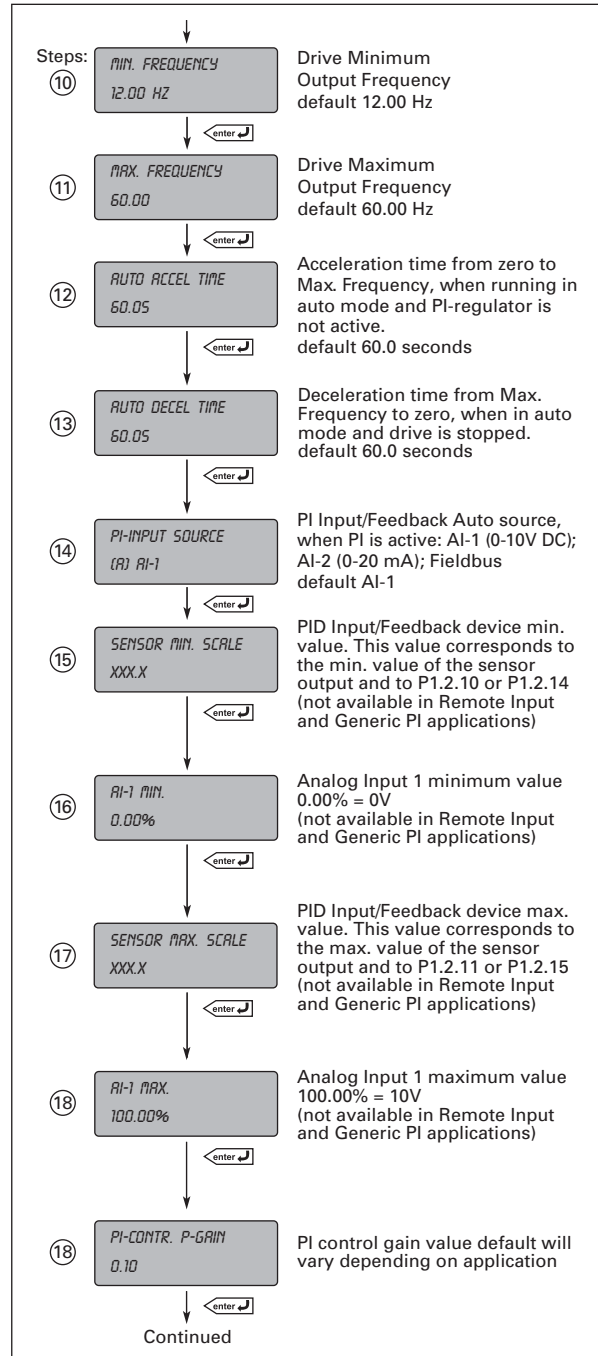

Figure 6: Start-Up Wizard Navigation (2 of 3)

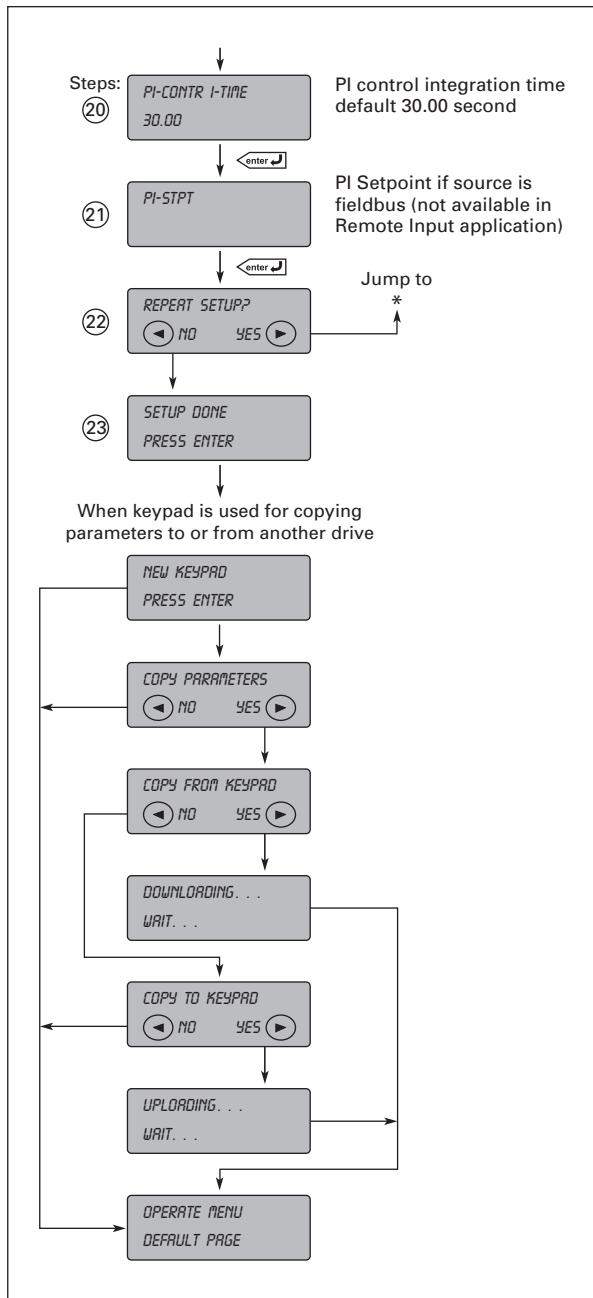

Figure 7: Start-Up Wizard Navigation (3 of 3)

Note: Start-Up Wizard can be cancelled with the STOP/RESET button. If pressed, the text "EXIT?" is shown on the display along with "No" and "Yes".

Note: In pressure applications Inverse Selection is an option.

Start-Up Wizard — Remote Input Application

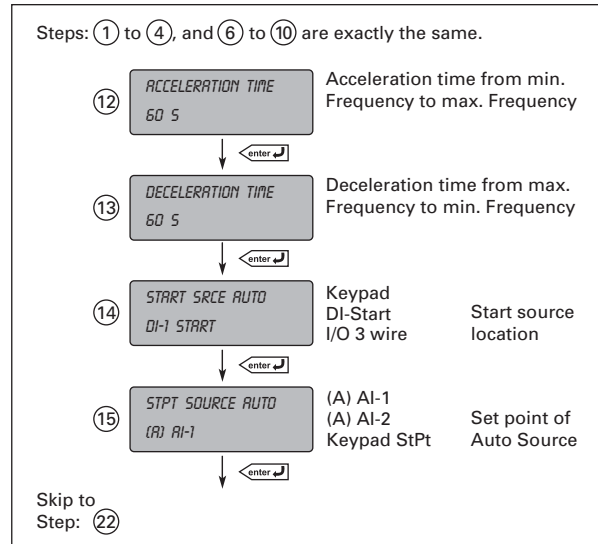

Figure 8: Remote Input Start-Up Wizard

System Menu Copy Parameter Options (S5.3)

The parameter copy function is used when the operator wants to copy one or all parameter groups from one drive to another. All the parameter groups are first uploaded to the keypad, then the keypad is connected to another drive and then the parameter groups are downloaded to it (or possibly back to the same drive).

Note: Before any parameters can successfully be copied from one drive to another, the drive must be stopped when the parameters are downloaded to it.

S5.3.1 Range: 0 – 4
Parameter Sets
PARAMETER SETS
 This parameter allows you to reload the factory default parameter values, and to store and load two customized parameter sets.

- 0 Load Factory defaults
- 1 Store Set 1
- 2 Load Set 1
- 3 Store Set 2
- 4 Load Set 2

S5.3.2
Upload to Keypad
UP TO KEYPAD
 This function uploads all existing parameter groups to the keypad.

S5.3.3 Range: 0 – 3 Default: 0 (All parameters)
Download from Keypad
DOWN FROM KEYPAD
 This function downloads one or all parameter groups from the keypad to the drive.

- 0 All parameters
- 1 All, no motor
- 2 Application parameters

Duct Static Application Example

Setpoint Feedback Keypad Default →

PI Feedback AI-1 0-10V DC Default →

Hand = Speed Ref
Auto = PID Control

OPTA9 Slot A

Close Terminal (6-8) to Start VFD

DI-1

DI-3

Damper/External Interlock

- Step 1 Wire Load, Line, Digital IN/OUT, Analog IN/OUT per **Page 3**
Verify Voltage & Amps
- Step 2 Static Check of Drive SCR, IGBT, DC Bus (Volt Meter)
- Step 3 Apply Power Proceed Start-Up Wizard per **Page 4**
- Step 4 HOA to Hand **enter**, to Test Direction of Motor
- Step 5 Press Start and **↑** to Increase Speed to Test Direction, Then Hit Stop
- Step 6 Change Multimonitor Display - - - - Next Page
- Step 7 HOA Twice to Auto Mode, Press Enter to Select, Press Start to Start PID Mode
- Step 8 Tune Gain PI

PROGRAMMING
PRESS ENTER

M1 PROGRAMMING
G1-G10

Once

G1.1 QUICK SETUP
P1-P25

Once

P1.1.1
PI FREQ
12.00 HZ

↓ to

P1.1.20
PI-CONT PI GAIN
##

Once

Blinking

Gain

enter

- Step 8.1 Return to Monitor

P1.1.20
PI-CONT PI GAIN
##

Twice

M1 PROGRAMMING
G1-G10

Once

M8 OPERATE MODE
PRESS ENTER

New Default

52 HZ

or Wait 60 Seconds and Screen Will Automatically go to

52 HZ

Multimonitor Menu Programming from Table 6-13 in User Manual LIT-1201828

Changing Multimonitor from R2.1 Keypad Reference, V7.1 Actual Speed, V7.2 Output Frequency to V7.22 PI Setpt, V7.21 PI Input & V7.2 Output Frequency. Please reference page 6-20 for information in LIT-1201828

R2.1
KEYPAD REFER
V7.2
OUTPUT FREQUENCY

V7.1
ACTUAL SPEED

V7.22
PI SETPT

V7.21
PI INPUT

V7.2
OUTPUT FREQUENCY

Default Multimonitor Screen New Multimonitor Screen

- Step 1

PROGRAMMING
PRESS ENTER

M1 PROGRAMMING
G1-G10

M7 MONITOR
V1-G25

V7.1 ACTUAL SPEED

V7.25 MULTIMONITOR

N7.25.1
R2.1 V7.1
V7.2 R2.1 Blinking ↑ Up to V7.1 V7.2 Blinking 7.21 3 Times

V7.1 Blinking V7.2 G7.25 MULTIMONITOR
M1-M7 M7 MONITOR
V1-G25 M8 OPERATE MODE
PRESS ENTER

Change Monitor Default Page to Actual Speed

- Step 1

PROGRAMMING
PRESS ENTER

M1 PROGRAMMING
G1-G10

M5 SYSTEM
MENU

S5.1 LANGUAGE

5.6 KEYPAD
SETTINGS

K5.6.1
DEFAULT PAGE_ P5.6.2
DEFAULT PAGE/DM Default Page Blinking 2 To Get Back

M5 SYSTEM
MENU M8 OPERATE MODE
PRESS ENTER

Refer to Table 6-14 in User Manual
Note: Output frequency will appear on keypad until Time-out Ref. P5.6.2.

Main Menu Navigation

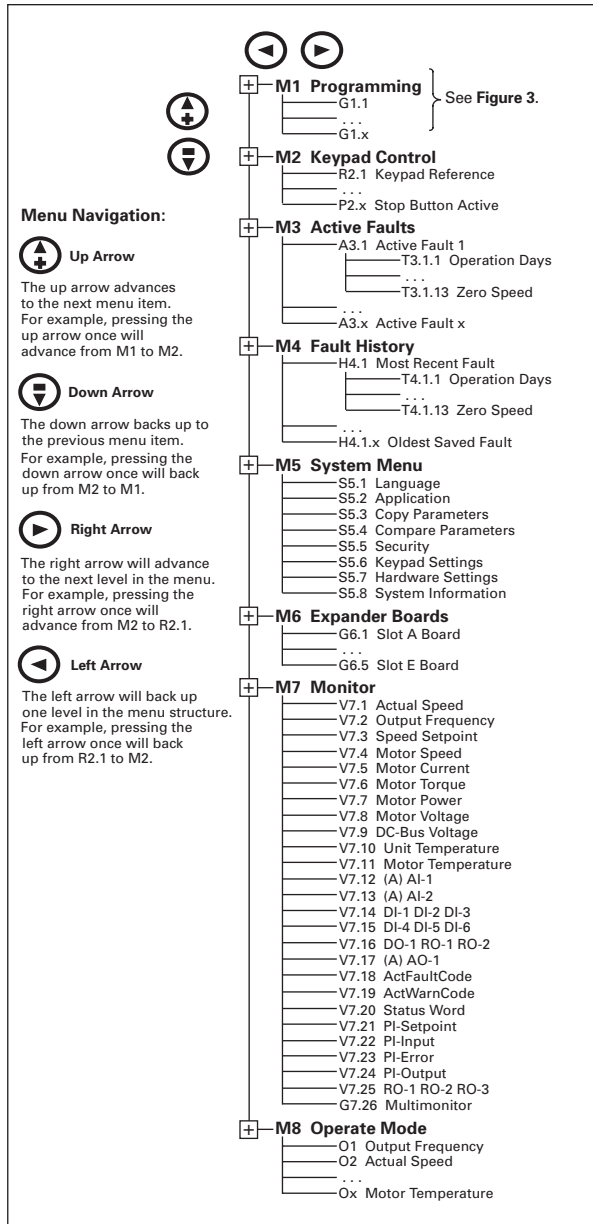

Figure 9: Main Menu Navigation

Parameter Menu Structure Example

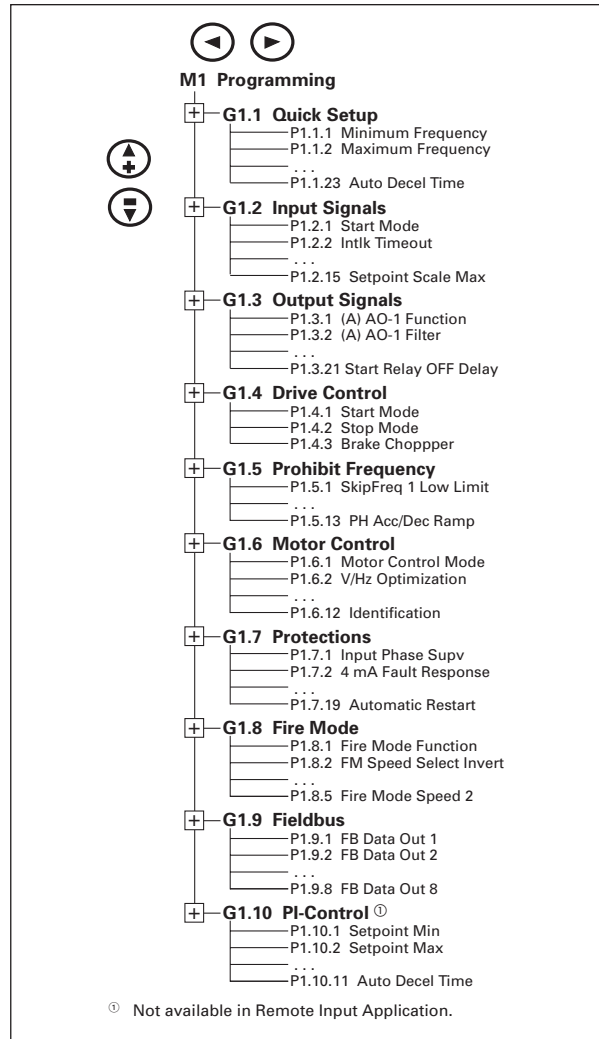

Figure 10: Parameter Menu Structure Example

Keypad Operation

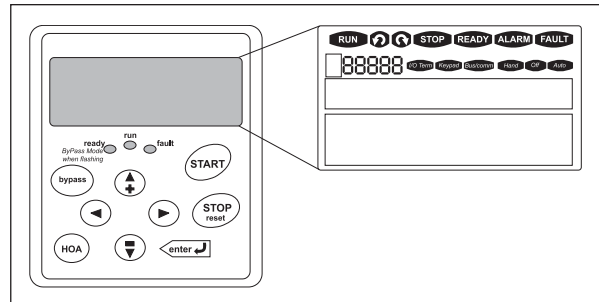

Figure 11: Keypad and Display

Power Ratings (Open Drives)

Table 1: 208/230V VT Output Power Ratings — Open Drive

Catalog Number ①	Frame Size	Three-Phase Input	
		Horsepower	Current
VSD0012x0A_ VSD152x0A_ VSD0022x0A_ VSD0032x0A_	FR4	1 1-1/2 2 3	4.8 6.6 7.8 11
VSD0052x0A_ VSD0072x0A_ VSD0102x0A_	FR5	5 7-1/2 10	17.5 25 31
VSD0152x0A_ VSD0202x0A_	FR6	15 20	48 61
VSD0252x0A_ VSD0302x0A_ VSD0402x0A_	FR7	25 30 40	75 88 114
VSD0502x0A_ VSD0602x0A_ VSD0752x0A_	FR8	50 60 75	140 170 205

① Insert a "1" for TYPE 1 or a "2" for TYPE 12 in place of the "x" in the Catalog Number.

Table 2: 480V VT Output Power Ratings — Open Drive

Catalog Number ②	Frame Size	Three-Phase Input	
		Horsepower	Current
VSD154x0A_ VSD0024x0A_ VSD0034x0A_ VSD0054x0A_ VSD0074x0A_	FR4	1-1/2 2 3 4 7-1/2	3.3 4.3 5.6 7.6 12
VSD0104x0A_ VSD0154x0A_ VSD0204x0A_	FR5	10 15 20	16 23 31
VSD0254x0A_ VSD0304x0A_ VSD0404x0A_	FR6	25 30 40	38 46 61
VSD0504x0A_ VSD0604x0A_ VSD0754x0A_	FR7	50 60 75	72 87 105
VSD1004x0A_ VSD1254x0A_ VSD1504x0A_	FR8	100 125 150	140 170 205
VSD2004x0A_ VSD2504x0A_	FR9	200 250	261 300

② Insert a "1" for TYPE 1 or a "2" for TYPE 12 in place of the "x" in the Catalog Number.

Table 3: 575V VT Output Power Ratings — Open Drive

Catalog Number ②	Frame Size	Three-Phase Input	
		Horsepower	Current
VSD0035x0A_ VSD0055x0A_ VSD0075x0A_ VSD0105x0A_	FR6	3 5 7-1/2 10	4.5 7.5 10 13.5
VSD0155x0A_ VSD0205x0A_ VSD0255x0A_ VSD0305x0A_	FR6	15 20 25 30	18 22 27 34
VSD0405x0A_ VSD0505x0A_	FR7	40 50	41 52
VSD0605x0A_ VSD0755x0A_ VSD1005x0A_	FR8	60 75 100	62 80 100
VSD1255x0A_ VSD1505x0A_ VSD2005x0A_	FR9	125 150 200	125 144 208

③ Insert a "1" for TYPE 1 or a "2" for TYPE 12 in place of the "x" in the Catalog Number.

Control Input/Output

Table 4: Remote Input Application Default I/O Configuration Main Control Board

Terminal	Signal	Description
OPTA9		
1	+10V DC _{ref}	Reference output Voltage for potentiometer, etc.
2	AI-1+	Analog input, voltage range 0 – 10V DC Voltage input frequency setpoint
3	AI-1-	I/O Ground Ground for reference and controls
4	AI-2+	Analog input, current range 0 – 20 mA Current input frequency setpoint
5	AI-2-	
6	24V DC	Control voltage output Voltage for switches, etc. max 0.1A
7	GND	I/O ground Ground for reference and controls
8	DI-1	Start/Stop Control Contact closed = start
9	DI-2	External fault input (programmable) Contact closed = fault Contact open = no fault
10	DI-3	External Interlock (programmable) Contact closed = OK Open = Interlocked
11	CMA	Common for DI-1 – DI-3 Connect to GND or 24V DC
12	24V DC	Control voltage output Voltage for switches (see terminal 6)
13	GND	I/O ground Ground for reference and controls
14	DI-4	PM Setback (programmable) Contact closed = PM setback active
15	DI-5	Fire Mode (programmable) Contact closed = Fire Mode active
16	DI-6	Overload relay (IntelliPass) (programmable) Contact open = no fault Contact closed = fault
17	CMB	Common for DI-4 – DI-6 Connect to GND or 24V DC
18	AO-1+	Output frequency Analog output Programmable Range 0 – 20 mA, R _L max. 500K
19	AO-1	
20	DO-1	Digital output READY Programmable Open collector, I A 50 mA, V A 48V DC
OPTA2		
21	RO-1	Relay output 1 Programmable Drive RUN is default.
22	RO-1	
23	RO-1	
24	RO-2	Relay output 2 Programmable Drive FAULT is default.
25	RO-2	
26	RO-2	

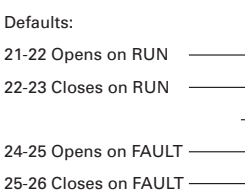
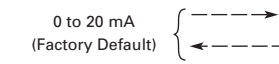
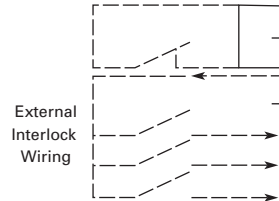
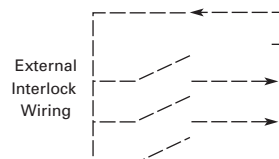
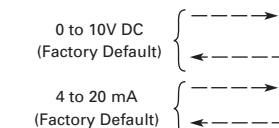

Note: For more information on jumper selections, see *User Manual LIT-1201828, Chapter 4.*

X3 Jumper Setting — CMA and CMB Grounding

- CMB Connected to Ground
CMA Connected to Ground
- CMB Isolated from Ground
CMA Isolated from Ground
- CMB and CMA Internally Connected
and Isolated from Ground

CAUTION

Unattended start will occur if power is supplied with Start Command activated.

Option Board A9 Jumper Location and Settings — Slot A

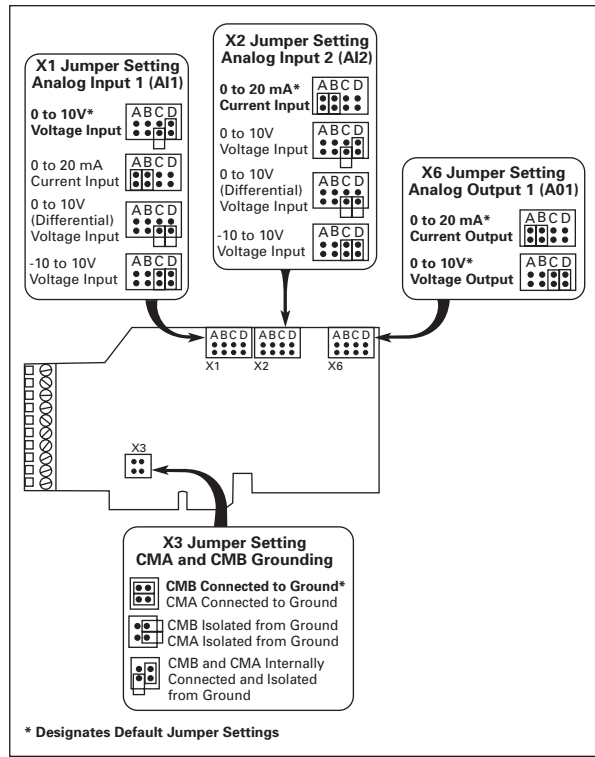

Figure 12: Option Board A9 Jumper Location and Settings

Fault and Warning Codes/Solutions

Table 5: Fault Codes

Fault Code	Fault	Possible Cause	Solution
1	Overcurrent	VSD Series drive has detected a high current (>4I _n) in its output due to: <ul style="list-style-type: none"> sudden heavy load increase short in the motor short in the cables to the motor unsuitable motor 	Check loading. Check motor. Check cables.
2	Overvoltage	The DC-link voltage has exceeded its high limit due to: <ul style="list-style-type: none"> too short a deceleration time high voltage levels or surges in the utility supply 	Make the deceleration time longer. Use brake chopper and brake resistor (standard on some models, available as options on others). Correct utility supply voltage (level is too high). Add input impedance to limit surges.
3	Ground (Earth) Fault	Current sensing indicates that the sum of motor phase currents is not zero. <ul style="list-style-type: none"> insulation failure in motor or motor cables 	Check motor and motor cables.
5	Charging Switch	The charging switch was open, when the START command was given due to: <ul style="list-style-type: none"> faulty operation component failure 	Reset the fault and restart. Should the fault re-occur, contact your Johnson Controls distributor.
6	Emergency stop	An Emergency stop signal was received from one of the digital inputs	Determine reason for the Emergency stop and remedy it.
7	Saturation trip	<ul style="list-style-type: none"> defective component motor or motor cable short 	Cannot be reset from the keypad. Switch off power. IF THE PROBLEM IS NOT IN THE MOTOR OR ITS CABLES, DO NOT RE-CONNECT POWER! Contact your Johnson Controls distributor. If this fault appears simultaneously with Fault 1, check the motor and motor cables.
8	System fault	<ul style="list-style-type: none"> component failure faulty operation Note: exceptional fault data record, see Active Fault Menu for more information	Reset the fault and restart. Should the fault re-occur, contact your Johnson Controls distributor.
9	Undervoltage	DC-link voltage is less than the minimum safe operating voltage limit <ul style="list-style-type: none"> most probable cause: too low a utility supply voltage VSD Series internal fault 	If there was a supply voltage loss or dip, reset the fault and restart the VSD Series drive. Check the supply voltage. If it was within specification at the time of the fault, an internal failure has occurred. Contact your Johnson Controls distributor.
10	Input line supervision	Input line phase is low or missing.	Check the utility supply voltage, cables and connections.
11	Output phase supervision	Current sensing indicates that there is no current in one motor phase	Check the motor cables, connections and motor.

Table 5: Fault Codes (Continued)

Fault Code	Fault	Possible Cause	Solution
12	Brake chopper supervision	<ul style="list-style-type: none"> no brake resistor installed brake resistor is broken brake chopper failure 	Check the brake resistor. If the resistor is ok, the chopper is faulty. Contact your Johnson Controls distributor.
13	VSD Series under-temperature	Heatsink temperature is under -10°C	Provide supplemental heating or relocate the VSD Series drive to a warmer location.
14	VSD Series overtemperature	Heatsink temperature is over 90°C.	<p>An overtemperature warning is issued when the heatsink temperature exceeds 85°C, a fault occurs at 90°C. Check for the correct amount and unrestricted flow of cooling air.</p> <p>Check the heatsink for dust or dirt buildup. Check the highest ambient temperature level.</p> <p>Make sure that the switching frequency is not set too high in relation to the ambient temperature and motor load.</p>
15	Motor stalled	<ul style="list-style-type: none"> motor or load mechanical failure load too high stall parameter settings incorrect 	Check the motor, mechanical system and load level. Confirm the stall parameter settings.
16	Motor overtemperature	<ul style="list-style-type: none"> motor is overloaded motor overheating has been detected by VSD Series motor temperature model 	Decrease the motor load. If no motor overload exists, check the temperature model parameters.
17	Motor underload	<ul style="list-style-type: none"> mechanical or load problem underload parameter settings incorrect 	Check the motor, check for a loose belt, broken coupling or load problems. Confirm underload parameter settings.
22 23	EEPROM checksum fault	<ul style="list-style-type: none"> Parameter save fault faulty operation component failure 	Upon reset of this fault, the VSD Series drive will automatically reload the parameter default settings. Check all parameter settings after reset. If the fault reoccurs, contact your Johnson Controls distributor.
25	Microprocessor watchdog fault	<ul style="list-style-type: none"> faulty operation component failure 	Reset the fault and restart. If the fault reoccurs, contact your Johnson Controls distributor.
26	Start-up prevented	Start-up of the drive has been prevented.	Check Start Enable/ Interlock settings.
29	Thermistor fault	The thermistor input of an option board has detected a high motor temperature	<p>Check the motor cooling and the motor loading.</p> <p>Check the thermistor connection.</p> <p>(If the thermistor input of an option board is not being used, it must be short-circuited.)</p>
31	IGBT temperature hardware	IGBT Inverter Bridge overtemperature protection has detected high short term overload current	Check loading. Check motor size.
32	Fan cooling	The VSD Series cooling fan did not start when commanded	Contact your Johnson Controls distributor.

Table 5: Fault Codes (Continued)

Fault Code	Fault	Possible Cause	Solution
34	CAN bus communication	Sent message not acknowledged	Ensure that there is another device on the bus with the appropriate configuration.
36	Control unit	Control unit cannot control the power unit and vice-versa	Change control unit.
37	Device change	<ul style="list-style-type: none"> option board changed different power rating of drive 	Reset. Note: No fault time data record!
38	Device added	<ul style="list-style-type: none"> option board added drive of different power rating added 	Reset. Note: No fault time data record!
39	Device removed	<ul style="list-style-type: none"> option board removed drive removed 	Reset. Note: No fault time data record!
40	Device unknown	Unknown option board or drive	Contact your Johnson Controls distributor.
41	IGBT temperature software	IGBT Inverter Bridge overtemperature protection has detected high short term overload current	Check loading. Check motor size.
42	Brake resistor overtemperature	Brake resistor overtemperature protection has detected excessive braking	Set the deceleration time longer. Use an external brake resistor.
43	Encoder fault	<p>Note: the exceptional Fault data record. See Active Fault Menu for more information. Additional codes:</p> <ol style="list-style-type: none"> Encoder 1 channel A is missing Encoder 1 channel B is missing Both encoder 1 channels are missing Encoder reversed 	Check encoder channel connections. Check the encoder board.
50	Analog input $I_{in} < 4 \text{ mA}$ (for signal range 4 to 20 mA)	Current at the analog input is $< 4 \text{ mA}$ <ul style="list-style-type: none"> control cable is broken or loose signal source has failed 	Check the current loop, signal source and wiring.
51	External fault	Digital input set as an external fault input has been triggered.	Check source of trigger.
52	Keypad communication fault	The connection between the control keypad and the VSD Series drive has been lost.	Check keypad connection and keypad cable.
53	Communication bus fault	The data connection between the communication bus master and the communication bus board has failed	Check installation. If installation is correct, contact your Johnson Controls distributor.
54	Slot fault	Defective option board or slot	Check that the board is properly installed and seated in slot. If installation is correct, contact your Johnson Controls distributor.
82	BypassOverLoad	The motor has been overloaded while connected to the bypass	Decrease the motor load. Disable the Current Imbalance feature – see the <i>IT</i> manual.

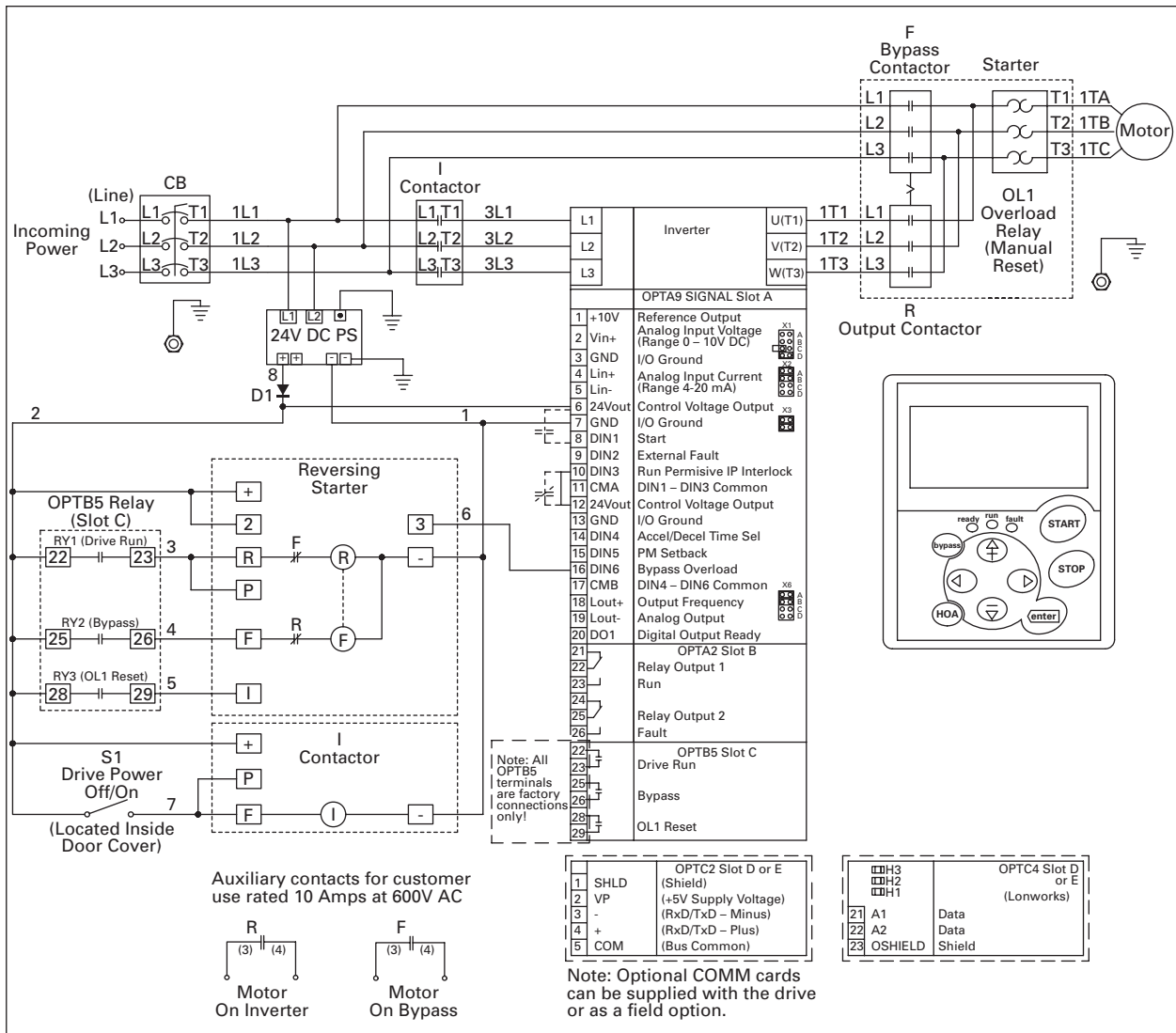

Figure 13: IntelliPass 3 Contactors