

V48 Series 3-Way Water Regulating Valves For Cooling Tower Systems

Application

IMPORTANT: The V48 Series Water Regulating Valve is intended to control water flow under normal operating conditions. Where failure or malfunction of the V48 Valve could lead to personal injury or property damage to the controlled equipment or other property, additional precautions must be designed into the control system. Incorporate and maintain other devices, such as supervisory or alarm systems or safety or limit controls, intended to warn of or protect against failure or malfunction of the V48 Valve.

V48 3-way pressure actuated water regulating valves are for condensing units cooled by atmospheric or forced draft cooling towers. They may be used on single, or multiple condenser hookups to the tower to provide the most economical and efficient use.

Low refrigerant head pressure, which may be the result of low tower water temperature, causes the cooling ability of the refrigeration system to fall off rapidly. The 3-way valve senses the compressor head pressure and allows cooling water to flow to the condenser, by-pass the condenser, or, flow to both the condenser and by-pass line to provide correct refrigerant head pressures. With the correct valve size (see Selection of Valve Size) and adequate pump capacity, the valve will provide refrigerant condensing temperatures between 90°F (32°C) and 105°F (41°C) with cooling tower water temperatures of 85°F (29°C) and 40°F (4°C).

⚠ WARNING

This product is made of copper alloy, which contains lead. The product is therefore not to be used on drinking water.

The 3-way valve permits water flow to the tower through the by-pass line, even though the condenser does not require cooling. This provides an adequate head of water at the tower at all times so the tower can operate efficiently with a minimum of maintenance on nozzles and wetting surfaces.

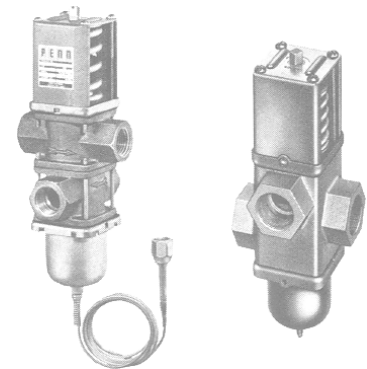

Fig. 1 -- (Left) 3-Way Valve sizes 1/2 in. through 1-1/4 in. (Right) 3-Way Valve size 1-1/2 in.

Specifications

| | | |
|--|--|--|
| Type Number | V48AB | 1/2" NPT |
| | V48AC | 3/4" NPT |
| | V48AD | 1" NPT |
| | V48AE | 1 1/4" NPT |
| | V48AF | 1 1/2" NPT |
| Range (Opening Point of Normally Closed Side) | R-12 | 85 to 110 PSIG (586 to 750 kPa) |
| | R-22 | 145 to 190 PSIG (1000 to 1310 kPa) |
| Maximum Permissible Pressure | R-12 | 230 PSIG (1586 kPa) |
| | R-22 | 320 PSIG (2206 kPa) |
| Water Supply Pressure | 150 PSIG (1034 kPa) Maximum | |
| Water Supply Temperature | 170°F (77°C) Maximum | |
| Material | Body | 1/2" and 3/4" Sizes – Cast Brass 1" and 1 1/4" Sizes – Cast Iron With Corrosion Resistant Finish 1 1/2" Sizes – One Piece Cast Iron Body With Corrosion Resistant Finish |
| | Disc Holder, Seat, Extension Sleeve | Aluminum Bronze |
| Factory Settings | See Table | |
| Sensing Element | Brass Bellow in Brass Cup | |
| Set Point Adjustment | Square Adjustment Shaft, Use a Standard Refrigeration Service Valve Wrench | |
| Packaging | Individual Pack | |

Features

- No close fitting sliding parts in water.
- Range spring does not come in contact with the cooling water.
- Easy manual flushing, if required.
- Valves will not chatter.
- Free movement of all parts provides accurate pressure modulation.
- Adjustment not affected by water pressure variations.
- Withstands high hydraulic shock without damage.
- Reduces problems of water distribution on multiple unit applications.

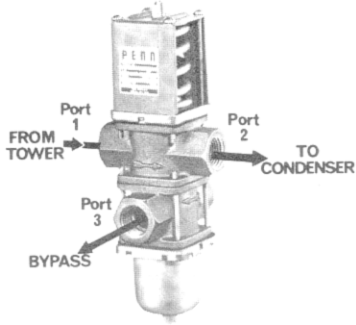

Fig. 2 -- Water flow of 1/2 in. through 1-1/4 in. valves.

General Description

The V48 valves are supplied in 1/2 in., 3/4 in., 1 in., 1-1/4 in., and 1-1/2 in. sizes for R-12 or R-22 as specified. The range spring and sliding parts are not immersed in water where they would be subject to sedimentation and corrosion. Only three internal parts come in contact with the water, and each of these parts, the valve disc holder, the valve seat, and extension sleeve, is made of corrosion resistant aluminum bronze.

The valves are factory adjusted for the settings shown in the "Factory Settings" table. The settings can be raised or lowered, as required. Both the condensing and by-pass settings are changed by an equal amount.

Factory Settings

| Refrigerant | Opening Pressure Port 1 to Port 2* (To Condenser) | Closing Pressure Port 1 to Port 3* (To By-Pass) |
|-------------|---|---|
| R-12 | 95 PSIG (655 kPa) | 130 PSIG (896 kPa) |
| R-22 | 165 PSIG (1138 kPa) | 215 PSIG (1482 kPa) |

* See Figs. 2 and 3 for Port arrangements.

Shipping Weights

| Size | Individually Packed Lb (kg) | Overpack of 10 Units per Carton Lb (kg) |
|--------|-----------------------------|---|
| 1/2" | 5 (2.3) | 52 (23.6) |
| 3/4" | 6 1/2 (2.9) | 67 (30.4) |
| 1" | 12 (5.4) | — |
| 1 1/4" | 16 (7.3) | — |
| 1 1/2" | 25 (11.3) | — |

Product Number Selection

| Valve Size NPT | Product Number | | Pressure Connections |
|----------------|----------------|---------|--|
| | R-12 | R-22 | |
| 1/2" | V48AB-1 | V48AB-2 | 30" (762 mm) Capillary With 1/4" Flare Nut |
| 3/4" | V48AC-1 | V48AC-2 | |
| 1" | V48AD-1 | V48AD-2 | |
| 1 1/4" | V48AE-1 | V48AE-2 | 1/4" SAE Male Flare |
| 1 1/2" | V48AF-1 | V48AF-2 | |

The V-48 may be manually flushed by lifting the range spring follower with screwdrivers at the two sides of the lower spring cap. This does not affect the valve adjustment.

Optional Constructions

Capillary Tubing Length

Standard length 30 in. (762 mm).
Optional 48 in. (1219 mm)
capillary furnished at additional cost, when specified, quantity orders only.

Temperature Actuated Valves

Write to Customer Service.

Selection of Valve Size

Refer to the Flow Chart for selection of water valves. Carefully follow the steps outlined below.

1. Determine the maximum water flow required through the condenser.

- a. Check the condenser manufacturer's recommendations for water flow, or use the recommended condenser water temperature rise determined by using the following calculation.

$$\text{gallons/min/ton} = \frac{30}{(\text{water outlet temp.} - \text{water inlet temp.})}$$

- b. The normal flow through a condenser used with a cooling tower is 3 gallons/min/ton.
- c. Total flow (gallons/min) = tons of refrigeration x gallons/min/ton.

2. Draw a horizontal line across the upper half of the Flow Chart through the required flow as determined by 1-C above.

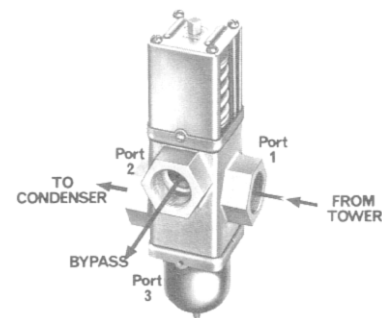

Fig. 3 -- Water flow of 1-1/2 in. valve.

Required Pump Flow In (GPM)

| Pressure Drop PSIG (kPa) | Valve Size | | | | |
|--------------------------|------------|------|------|--------|--------|
| | 1/2" | 3/4" | 1" | 1 1/4" | 1 1/2" |
| 7 (48) | 8 | 20 | 27.5 | 38 | 53 |
| 10 (69) | 10 | 23 | 32.5 | 46 | 64 |
| 15 (103) | 12.5 | 28 | 39 | 56 | 78 |

- Determine the refrigerant head pressure rise above the valve opening point. It is considered good practice in most applications to provide a condensing temperature between 90°F (32°C) and 105°F (41°C). This corresponds to a pressure range of 100 to 130 PSIG (690 to 896 kPa) on R-12 and 170 to 215 PSIG (1172 to 1482 kPa) on R-22. In general, therefore, the refrigerant head pressure rise above the opening point should be 30 PSIG (207 kPa) with R-12 and 45 PSIG (310 kPa) with the R-22. Some manufacturers recommend a slightly higher head pressure range.
- Note that there are two vertical pressure scales in the lower half of the Flow Chart; one for R-12 and one for R-22. Draw a horizontal line across the lower half of the Flow Chart through the value determined in Step 3. Be sure to use the correct scale.
- Determine the allowable water pressure drop through the valve. The pumping head should include the pressure drop through the valve (7 PSIG [48 kPa] = 16 ft, 10 PSIG [69 kPa] = 23 ft, 15 PSIG [103 kPa] = 35 ft).
- On the lower half of the curve, mark the point on the horizontal head pressure line where it intersects the allowable water pressure drop curve.
- From this point, draw a line vertically upward until it intersects the water flow line in the upper half of the Flow Chart.

- If the intersection falls on a valve size, this is the correct size.
- If the intersection falls between two curves, the required valve size is the larger of the two.

Example

- The required flow for an R-22 system is found to be 21 gpm. It is desirable to operate at a condensing temperature between 90°F (32°C) and 105°F (41°C). Head pressure will be between 170 and 215 PSIG (1172 and 1482 kPa). Allowable water pressure drop is 7 PSIG (48 kPa).
- Draw a line through 21 gpm – see the dotted line, upper half of the Flow Chart.
- Draw a line through the head pressure rise of 45 PSIG (310 kPa) – see the dotted line, lower half of the Flow Chart.
- At the intersection of the lower horizontal line and the pressure drop of 7 PSIG (48 kPa), draw a vertical line upward from this point to the

flow line – the circle on the Flow Chart marks this intersection.

- This intersection falls between the curves for 3/4 in. and 1 in. valves. A 1 in. valve is required.

Note: If a head pressure rise above the valve opening point is chosen at less than 45 PSIG (310 kPa) for R-22 or less than 30 PSIG (207 kPa) for R-12, the condenser by-pass will be partly open when the desired maximum flow is obtained through the condenser. In these cases, the pump flow required should be taken from the “Required Pump Flow” table.

Ordering Information

To order specify:

- Product Number (see “Product Number Selection” chart).
 - “Selection of Valve Size” for instructions on selection.

Repairs and Replacement

Field repairs must not be made except for replacement of the sensing element, internal parts, and the rubber diaphragms. For a replacement valve or a complete renewal seat kit, contact the nearest Johnson Controls® wholesaler. Replacement part kit numbers are shown in the “Replacement Parts” table.

Replacement Parts

| Valve Product Number | Replacement Power Element | Renewal Parts Kit** |
|----------------------|------------------------------|---------------------|
| V48AB-1, -2 | SEP91A-602R and SEC37A-602R* | STT15A-605R |
| V48AC-1, -2 | SEP91A-601R and SEC37A-602R* | STT16A-604R |
| V48AD-1, -2 | SEP91A-603R and SEC37A-600R* | STT17A-616R |
| V48AE-1, -2 | SEP91A-603R and SEC37A-600R* | STT17A-617R |
| V48AF-1 | SEP81A-602R | STT17A-604R |
| V48AF-2 | SEP81A-601R | STT17A-604R |

* Replacement element includes “SEP91A” element with 1/4” male SAE connector and “SEC37A” capillary kit with 2 flare nuts. (Use only on valves specified.)

** Kits include all internal parts and diaphragms required to recondition valves.

FLOW CHART R-12 AND R-22 REFRIGERANTS

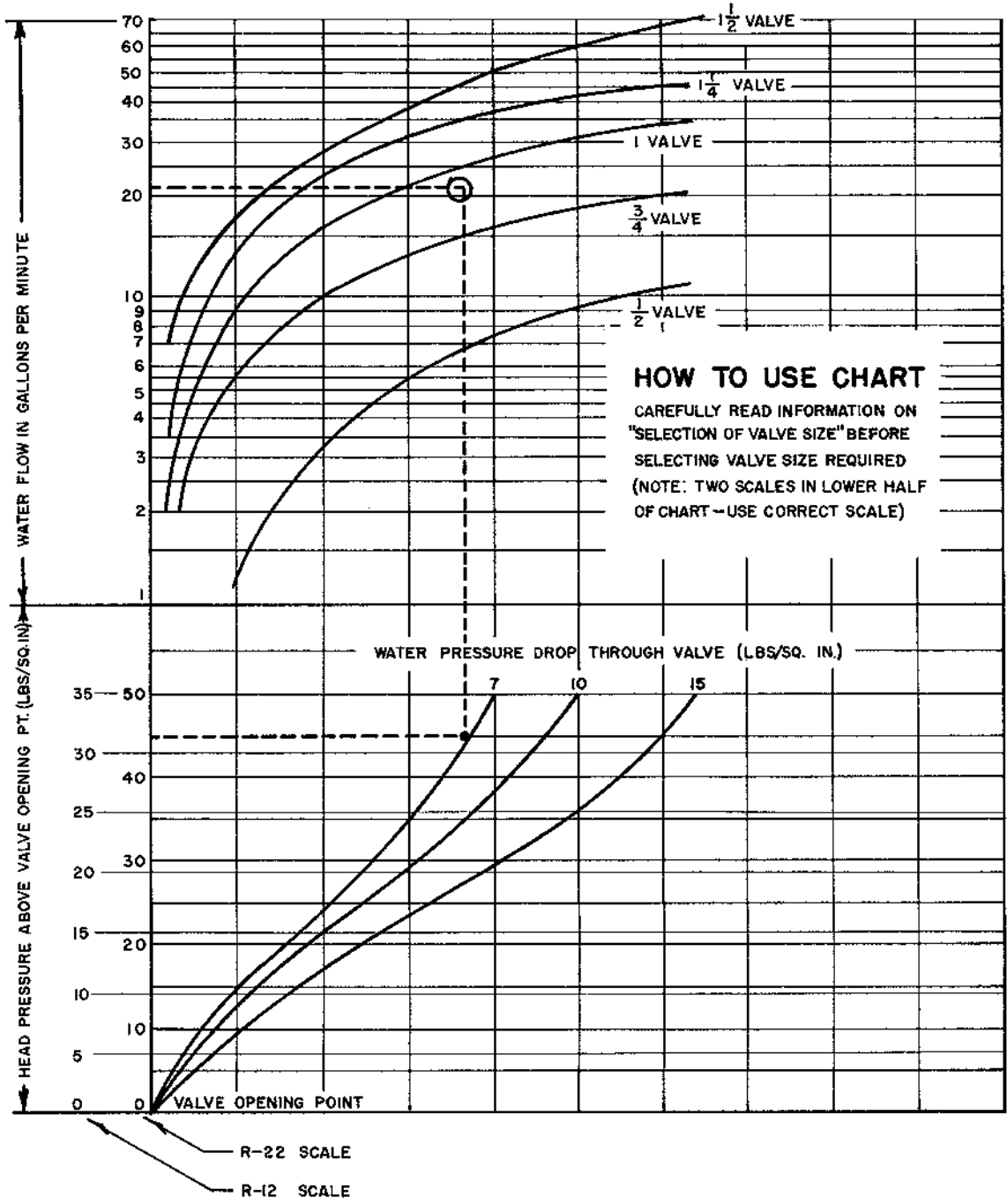

Installation

1. Install the 3-way water valve as shown in Fig. 4. Port 1 is for the connection from the tower; Port 2 is for the connection to the condenser inlet, and Port 3 is the by-pass connection.
2. With the tower pump operating and the compressors shut down, manually flush each valve by lifting the range spring follower with screwdrivers at two sides of the lower spring cap. This does not affect valve adjustment.
3. When used on a single condenser system, the square head cock in the by-pass should be adjusted with the compressor shut down and the tower pump operating. Adjust the cock so that the amount of water through the by-pass is just sufficient to provide the minimum recommended nozzle pressure.
4. On a multiple condenser system, the square head cocks in the by-passes should be adjusted evenly with the compressors shut down and the tower pump operating. The total flow through all the by-passes should be just sufficient to provide the minimum recommended nozzle pressure.
5. The R-22 valves are factory set to start flow to the condenser at 165 PSIG (1138 kPa) and be fully open at 215 PSIG (1482 kPa). The R-12 valves are factory set to start flow to the condenser at 95 PSIG (655 kPa) and be fully open at 130 PSIG (896 kPa). The opening point may be increased or decreased by turning the adjustment screw counter-clockwise or clockwise, respectively. Any increase or decrease in the opening point will result in a like increase or decrease in the pressure at which the valve is fully open to the condenser.

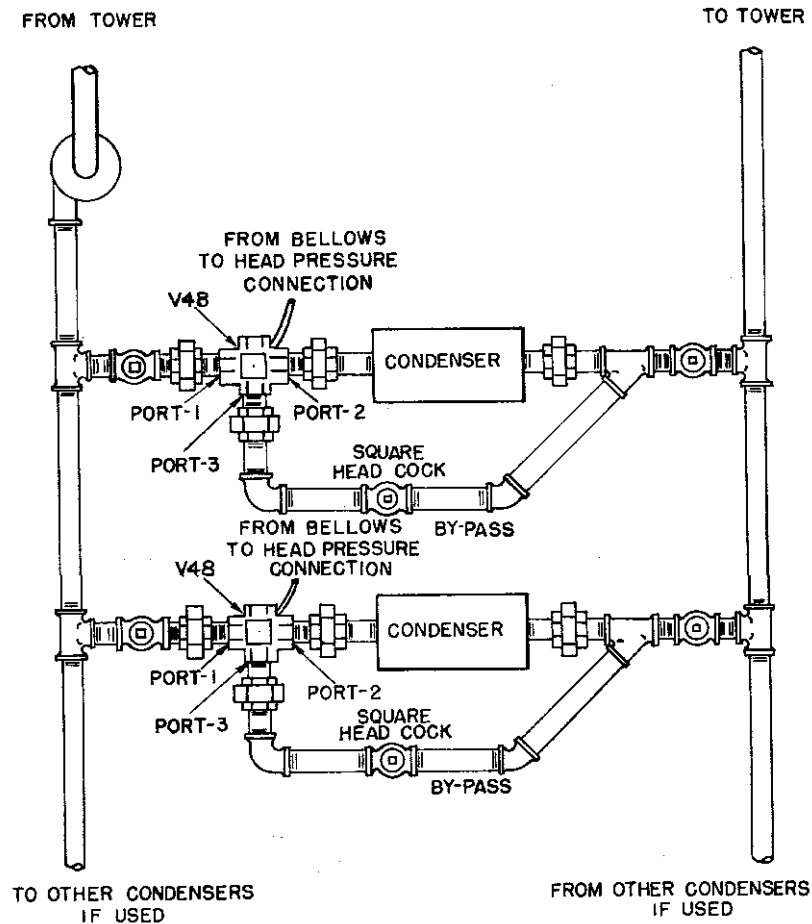
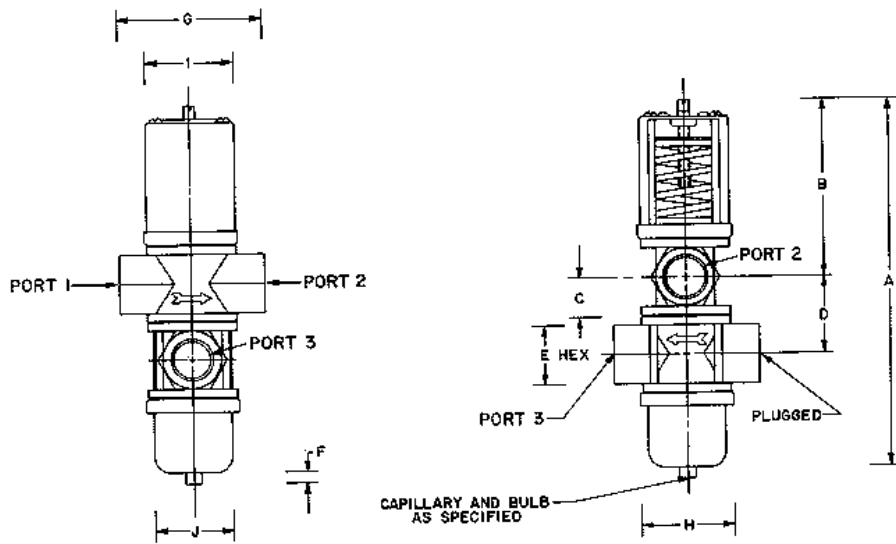
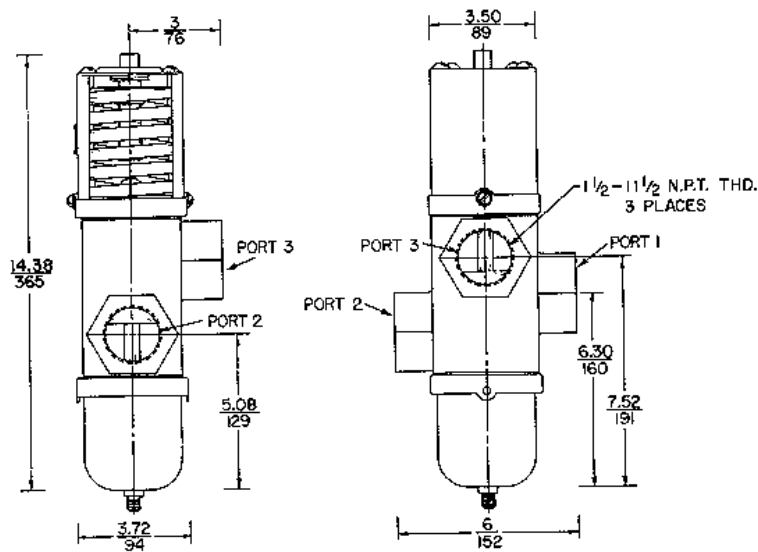

Fig. 4 — Recommended piping arrangement.



| Valve Size | A | B | C | D | E | F | G | H | I | J |
|------------|-------|------|------|------|------|-----|------|------|------|------|
| 1/2" | 7.88 | 3.75 | .77 | 1.53 | 1.13 | .28 | 3.13 | 2.16 | 1.84 | 1.75 |
| | 200 | 95 | 20 | 39 | 29 | 7 | 80 | 55 | 47 | 44 |
| 3/4" | 8.56 | 4.16 | .89 | 1.78 | 1.38 | .28 | 3.38 | 2.16 | 2.03 | 1.91 |
| | 217 | 106 | 23 | 45 | 35 | 7 | 86 | 55 | 52 | 49 |
| 1" | 11.91 | 5.94 | 1.02 | 2.03 | 2 | .28 | 4.84 | 2.78 | 2.63 | 2.31 |
| | 303 | 151 | 26 | 52 | 51 | 7 | 123 | 71 | 67 | 59 |
| 1 1/4" | 12.66 | 6.13 | 1.20 | 1.41 | 2.38 | .28 | 4.88 | 2.78 | 2.63 | 2.31 |
| | 322 | 156 | 30 | 36 | 60 | 7 | 124 | 71 | 67 | 59 |



Dimensions $\frac{\text{in.}}{\text{mm}}$

Performance specifications appearing herein are nominal and are subject to accepted manufacturing tolerances and application variables.

Notes

Notes



® Johnson Controls and PENN are registered trademarks of Johnson Controls in the United States of America and/or other countries. All other trademarks used herein are the property of their respective owners. © Copyright 2018 by Johnson Controls. All rights reserved.