

## MR4PMUHV Electronic Temperature/Defrost Control with Relay Pack

*The MR4PMUHV Temperature/Defrost Control with Relay Pack controls the temperature and defrost cycles on commercial refrigeration and freezer applications. The control allows a hot gas or electric heat defrost cycle and uses time or temperature to control defrost termination.*

*The MR4PMUHV Temperature/Defrost Control incorporates temperature management, defrost management, evaporator fan management, and alarm management control functions. One convenient package consolidates the functions of a thermostat, a digital display, a timer, and a defrost termination switch.*

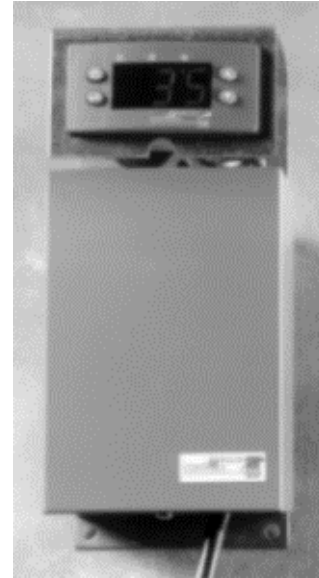

**Figure 1: MR4PMUHV Electronic  
Temperature/Defrost Control with Relay Pack**

Features and Benefits	
<input type="checkbox"/> <b>Single Package</b>	Provides the functionality of multiple control components at a cost-effective price.
<input type="checkbox"/> <b>Easily Readable Display</b>	Displays main sensor or auxiliary sensor temperatures; helps troubleshoot system. Provides alarm codes.
<input type="checkbox"/> <b>Accurate, Interchangeable Temperature Sensor</b>	Provides accurate control performance with up to 300 feet (91 m) of sensor wiring. (A temperature offset function may be set to accommodate applications with longer sensor wire leads.)
<input type="checkbox"/> <b>Heavy-Duty Relays</b>	Allow direct control of compressors, fans, and heaters. Reduce installation time.
<input type="checkbox"/> <b>Nonvolatile Memory</b>	Retains user-programmed settings in event of power loss.
<input type="checkbox"/> <b>Alarm Management Functions</b>	Provide alarm codes and a relay to either operate a remote alarm or trigger a dial-out modem.

## Federal Communications Commission (FCC) Compliance Statement

This equipment has been tested and found to comply with the limits for a Class A digital device pursuant to Part 15 of the FCC Rules. These limits are designed to provide reasonable protection against harmful interference when the equipment is operated in a commercial environment. This equipment generates, uses, and can radiate radio frequency energy and, if not installed and used in accordance with the instruction manual, may cause harmful interference to radio communications. Operation of this equipment in a residential area is likely to cause harmful interference, in which case the user is required to correct the interference at his/her own expense.

## Canadian Compliance Statement

This digital apparatus does not exceed the Class A limits for radio noise emissions from digital apparatus set out in the Radio Interference Regulations of the Canadian Department of Communications.

## Application

**IMPORTANT:** The MR4PMUHV Temperature/Defrost Control is intended to control equipment under normal operating conditions. Where failure or malfunction of the MR4PMUHV control could lead to an abnormal operating condition that could cause personal injury or damage to the equipment or other property, other devices (limit or safety controls) or systems (alarm or supervisory systems) intended to warn of, or protect against, failure or malfunction of the MR4PMUHV control must be incorporated into and maintained as part of the control system.

The MR4PMUHV Temperature/Defrost Control consolidates the functions of a temperature control, a digital temperature readout, a defrost cycle timer, and a defrost termination device.

The MR4PMUHV control provides direct control in many refrigeration applications. See electrical ratings in Tables 6 through 8 for more information.

## Operation

The MR4PMUHV Control performs the following functions:

### Temperature Management

Several settings define the temperature control functions:

- **Setpoint** and **Differential** settings establish the controlled temperature and acceptable temperature range.
- **Cycle Delay** establishes a set time interval between compressor restarts to avoid excessive cycling.
- **Deep Freeze Time** establishes the duration of a manually-initiated freeze cycle.
- **Sensor Failure Operation** initiates a predefined response to a temperature sensor failure.

### Alarm Management

Several settings define the control functions for alarms:

- **High and Low Temperature Alarms** provide notification of temperatures that exceed user-designated high and low limits.
- **Alarm Time Delay** keeps short-duration temperature changes from triggering an alarm.
- **Alarm Differential** keeps the alarm from cycling rapidly on and off due to minor temperature fluctuations.
- **Alarm Codes** assist in troubleshooting.

### Defrost Cycle Management

The MR4PMUHV Temperature/Defrost Control allows a hot gas or electric heat defrost cycle, and uses time or temperature to control defrost termination.

### Evaporator Fan Management

These settings define the control functions for evaporator fans:

- **Fan Operating Mode** controls whether evaporator fans run continuously or only when the compressor is on.
- **Fan Start-Up Delay** follows either time-based or evaporator-temperature-based startup after defrost. In a timed-defrost application, a properly-wired reversible fan motor can run in reverse, bringing warm air over the evaporator coils.

## Binary Input Response

**Binary Input Function** allows the user to select which output relays respond to a binary input (switch) if the binary input contacts are open for a time (in minutes) longer than the **Binary Input Time Delay**.

## Additional Features

The MR4PMUHV control uses several other settings to control specific features:

- **Keyboard locking** disables/enables change of the setpoint and other functions, reducing accidental or unauthorized changes of the control settings.
- **Self-Test Procedure** initiates a test cycle of all outputs and tests all Light-Emitting Diodes (LEDs). See *Initiating a Manual Self-Test*.
- **Manual Deep Freeze Cycle** manually initiates a deep freeze cycle, which is useful when loading a cold room or a display cabinet. See *Initiating a Manual Deep Freeze Cycle*.
- **Manual Defrost** interrupts normal control operation and initiates an immediate defrost cycle. See *Initiating a Manual Defrost Cycle*.

For additional information about control functions and how to program them, see *Programming the Control and Control Functions*.

## Control Module Front Panel

The control module has an LED display and buttons for entering programming information and activating various features.

The display has three LED digits. It displays a temperature range from -40 to 176°F (-40 to 80°C) in increments of 1°F or C°. The display also features three status LEDs.

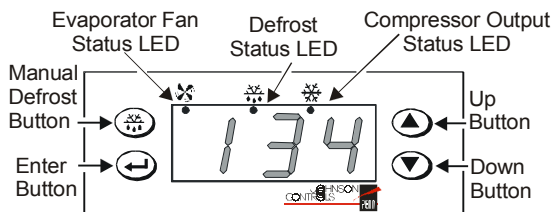

Figure 2: Control Module Front Panel

## Installation

See *Mounting and Wiring* for installation information.

## Dimensions

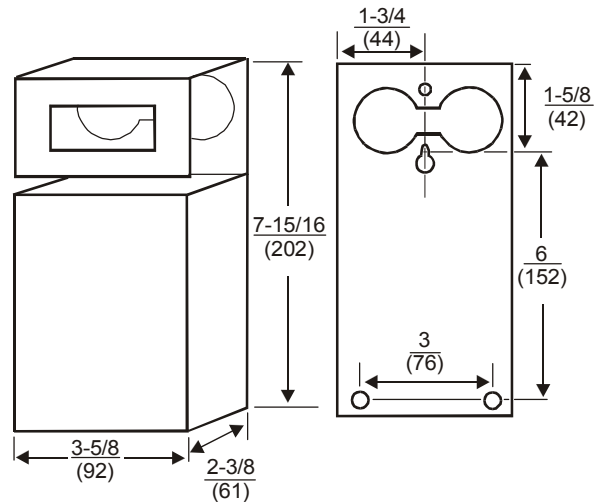

Figure 3: Relay Pack with Mounting Bracket Dimensions, in. (mm)

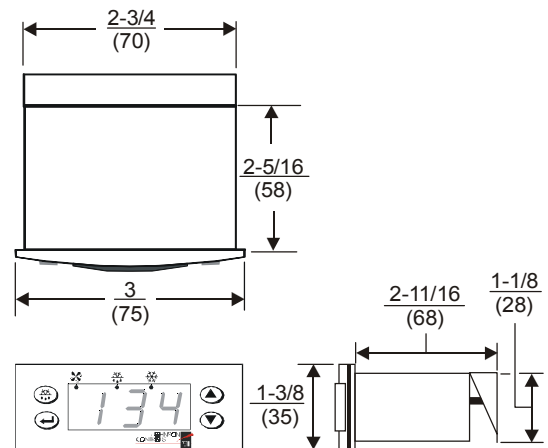

Figure 4: Control Module Dimensions, in. (mm)

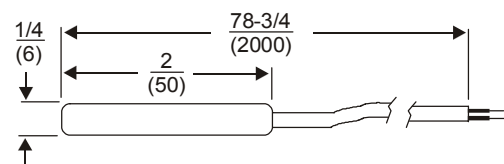

Figure 5: A99BB-200C Sensor Dimensions, in. (mm)

## Mounting

The MR4PMUHV control is not position sensitive. Mount the MR4PMUHV control as a single unit, or separate the control module and relay pack and mount them individually to allow convenient wiring and adjustment.

### Mounting the MR4PMUHV Control as a Single Unit

Before mounting the relay pack, ensure that there is sufficient space. Follow these steps to mount the relay pack:

1. Hold the MR4PMUHV control against the surface and use it as a template to trace the mounting slots.
2. Drill holes for mounting screws in the holes indicated.
3. Use three screws (No. 8 or No. 10 size) to mount the MR4PMUHV control.

### Mounting the Control Module and Relay Pack Separately

Mount the relay pack and the control module within 18 in. (46 cm) of each other.

### Removing the Control Module from the Relay Pack

Follow the steps to separate the control module and the relay pack. See Figures 6-7.

1. Locate the mounting clip that holds the control module to the mounting bracket on the relay pack.
2. Squeeze the forward portion of the mounting clip together and slide the mounting clip back to remove the mounting clip from the back of the control module.
3. Pull the control module out of the mounting bracket on the relay pack.
4. Disconnect the wiring from the control module and the relay pack terminals V1, V2, O1, and O2. See Figures 7-9.

### Mounting the Relay Pack

Before mounting the relay pack, ensure that there is sufficient space. Follow these steps to mount the relay pack.

1. Hold the relay pack with mounting bracket against the surface and use as a template to trace the mounting slots.

2. Drill holes for mounting screws in the slots indicated.
3. Use three screws (No. 8 or No. 10 size) to mount the relay pack.

### Mounting the Control Module

Before mounting the control module, ensure that there is sufficient free space [at least 2-3/4 inches (70 mm)] behind the mounting surface. Follow these steps to mount the control module.

1. Cut a hole 1-3/16 x 2-13/16 inches (29 x 71 mm).
2. Remove the retaining clip from the control module.
3. Insert the control module into the hole.
4. Install the retaining clip and slide forward to adjust for tightness.
5. Reconnect the wires on the terminals in the relay pack to the corresponding terminals on the control module. See Figures 7-9.

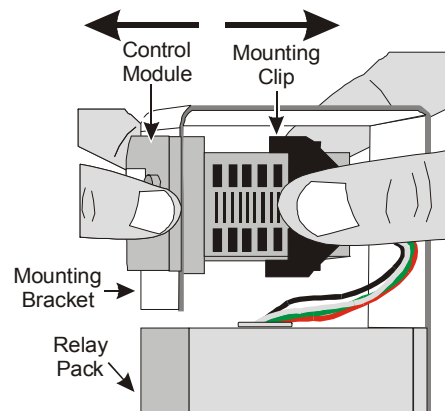

Figure 6: Removing the Mounting Clip and Control Module

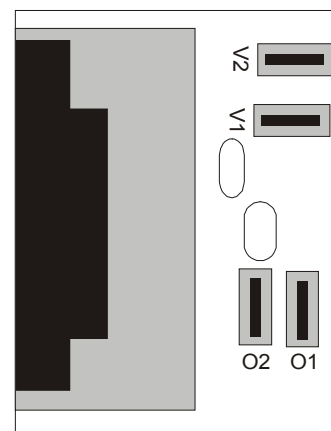

Figure 7: Relay Pack Terminal Positions on Circuit Board

## Wiring



### WARNING: Risk of Electric Shock.

To avoid electric shock or damage to equipment, disconnect all power supplies before wiring any connections. More than one disconnect may be necessary to completely de-energize equipment.

### Wiring Sensors and Binary Input

Wire the sensors and binary input (if used) as shown in Figures 8-9. The Sensor (S1 or S2) and Sensor Common (SC) wires are interchangeable when using the A99B temperature sensors. The binary input shares a common terminal with the sensors.

Note: Black boxes indicate unused terminals.

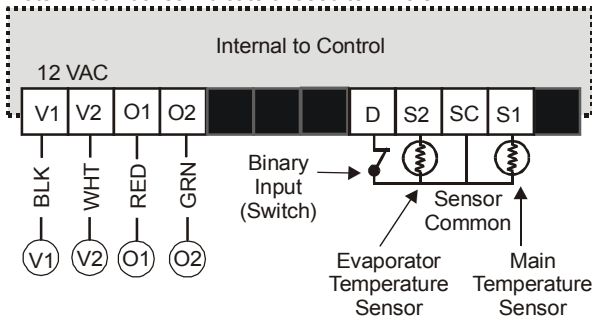
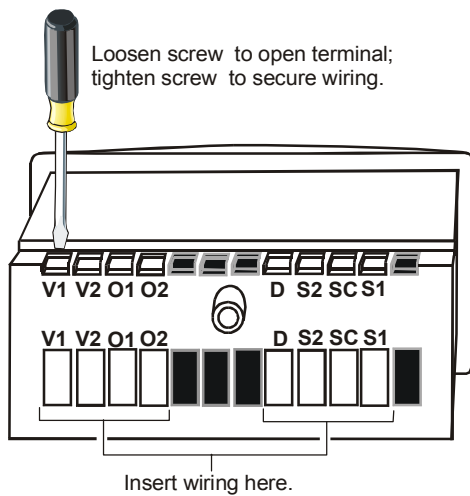

Figure 8: Wiring the Control Module



Note: Black boxes indicate unused terminals.

Figure 9: Rear View of the Control Module

Use **Temperature Sensor Offset** to compensate for sensor leads longer than 300 ft (if °F is used) or 165 m (if °C is used). See Table 1 and *Temperature Management Functions: Temperature Sensor Offset*.

Table 1: Sensor Wire Size and Length

Wire Size and Length			Offset
18 AWG	20 AWG	22 AWG	
300-599 ft	190-374 ft	120 -239 ft	1 F°
600-899 ft	375-564 ft	240-349 ft	2 F°
900+ ft	565+ ft	350+ ft	3 F°
165-329 m	105-204 m	65-129 m	1 C°
330-495 m	205-310 m	130-195 m	2 C°

### Wiring the Relay Pack



### WARNING: Risk of Electric Shock.

To avoid electric shock or damage to equipment, disconnect all power supplies before wiring any connections. More than one disconnect may be necessary to completely de-energize equipment.

See Figure 10 for arrangement of terminals on the terminal block in the relay pack. See Figures 11-12 for sample wiring diagrams.

Follow these wiring guidelines:

- Ensure all wiring conforms to the National Electric Code and local regulations.
- Use 14 AWG copper wire for motor loads up to 12 FLA and noninductive loads up to 15 A.
- Use 12 AWG copper wire with an insulation rating of 75°C (minimum) for motor loads up to 16 FLA and noninductive loads up to 20 A.
- Use wire no longer than 50 ft (15 m).
- Ensure all circuits have a common disconnect and are connected to the same pole of the disconnect.

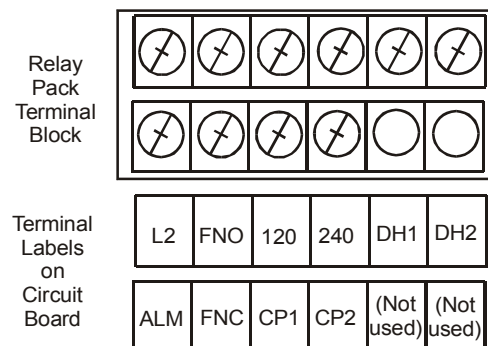
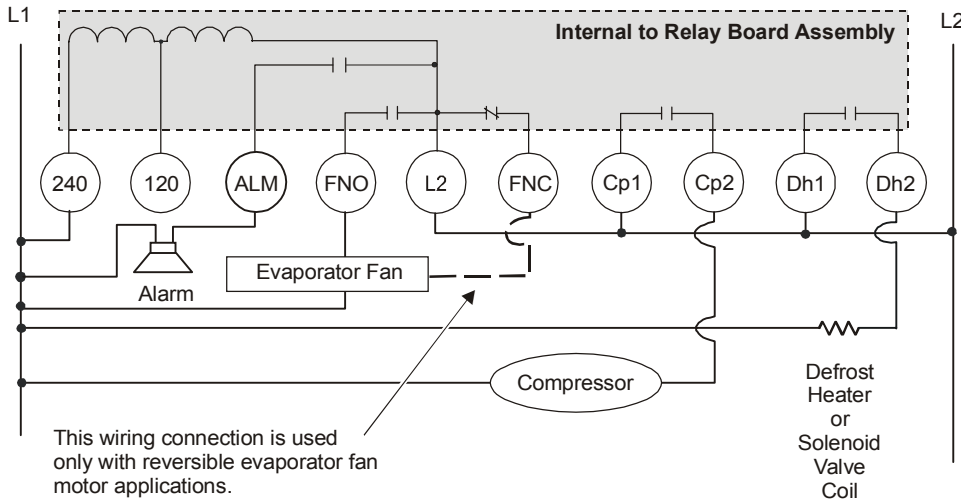

Figure 10: Relay Pack Terminal Block

Note: All circuits must have a common disconnect and be connected to the same pole of the disconnect.



**Figure 11: Typical 240 VAC Relay Pack Wiring Connections**

Note: All circuits must have a common disconnect and be connected to the same pole of the disconnect.

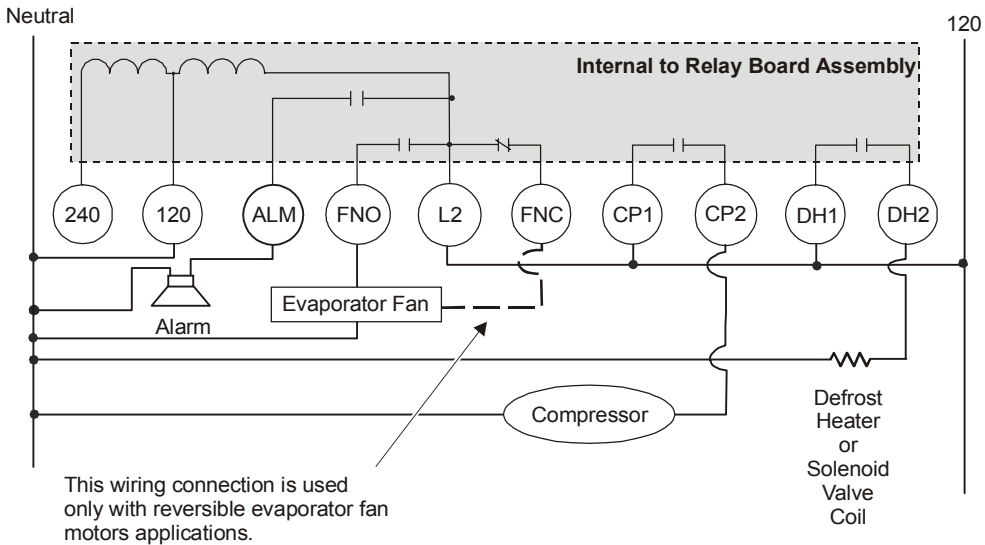

**Figure 12: Typical 120 VAC Relay Pack Wiring Connections**

## Programming the Control

Use this section to program the control module. After programming, the control module retains its programmed settings, even in the event of a power failure or power-down.

### Using the Control Module

During normal operation, the display shows the main sensor temperature. See Figure 2.

- Press Up or Down repeatedly to scroll through the main sensor temperature, evaporator sensor temperature and the binary input status.
- Press Enter to display the Setpoint.

After 15 seconds of inactivity, the display returns to main sensor temperature.

### Unlocking or Locking Access to Programming

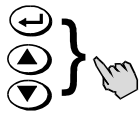

1. In sequence, press and hold Enter, Up, and then Down.
2. Hold these buttons until “- - -” displays.
3. Continue holding until the main sensor temperature displays (approximately 10 seconds).

### Changing the Setpoint

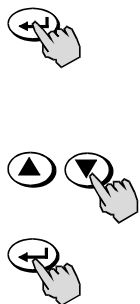

1. Press and hold Enter for approximately 3 seconds.
2. Release Enter when the new Setpoint value displays.
3. Press Up or Down to display the new Setpoint value.
4. Press Enter to save the new setting.

Note: The control ignores changes and reverts to the previous saved value unless you press Enter.

### Changing Other Function Values

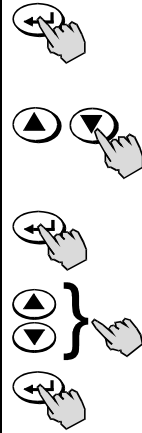

1. Press and hold Enter until **HY** (the code for Differential) appears (about 10 seconds). See Table 3.
2. Press Up or Down until the desired function appears. See Table 3 and *Control Functions*.
3. Press Enter. The function's existing value appears.
4. Press Up or Down until the desired setting value appears.
5. Press Enter to save the new value. After 10 seconds of inactivity, the display returns to normal operation.

Note: The control ignores changes and reverts to the previous saved value unless you press Enter.

### Initiating a Manual Self-Test

**IMPORTANT:** Disconnect controlled loads before running the self-test procedure. Reconnect controlled loads and cycle power to resume normal operation.

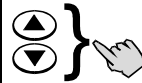

1. In sequence, press and hold Up and then Down.
2. Hold for 5 seconds.

### Initiating a Manual Defrost Cycle



Press and hold Defrost for 3 seconds to interrupt normal control operation and initiate a manual defrost cycle.

Note: If the Defrost Evaporator Temperature is higher than the Defrost Termination Temperature, the control does not initiate a manual defrost.

### Initiating a Manual Deep Freeze Cycle



1. In sequence, press and hold Enter and Up.
2. Hold both buttons for 5 seconds.
3. The compressor status LED lights and the compressor output relay contacts close.

## Control Functions

### Temperature Management Functions

**Setpoint** is the primary temperature setting (°F or °C) programmed by the user. When the sensed temperature drops to the Setpoint value, the Normally Open (N.O.) compressor relay contacts open, ending the On cycle. See Figure 13.

**HY Differential** is the difference (F° or C°) between Setpoint and the temperature at which the compressor relay contacts close, initiating the next On cycle. See Figure 13.

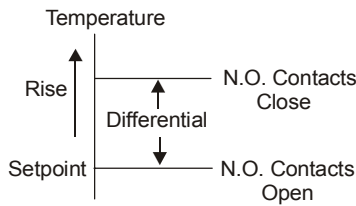

**Figure 13: Setpoint and Differential**

**HL, LL High and Low Setpoint Stops** are temperature values (°F or °C) that define high or low boundaries of Setpoint adjustment. Setpoint Stops deter unauthorized or accidental overadjustment of the Setpoint.

**CC Cycle Delay** establishes the minimum time (minutes) between subsequent On cycles of the compressor. See Figure 14.

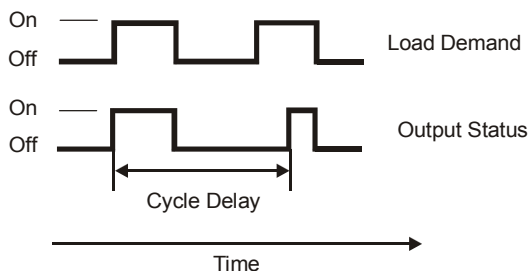

**Figure 14: Cycle Delay**

**Co Deep Freezing Time** overrides Setpoint temperature control and closes the compressor relay contacts for a user-defined time (minutes). Typically, this function is used to run the compressor continuously during periods of high refrigeration load to bring the sensed temperature below Setpoint and deep-freeze the product.

**SF Sensor Failure Operation** establishes how the compressor relay contacts operate in the event of a sensor-related failure. The compressor can remain Off, remain On, or cycle based on the average of the last four cycles.

In determining the average of the last four cycles, the control ignores deep freezing cycles, defrost cycles, and the first cycle after a deep freeze cycle or a defrost cycle.

**So Temperature Sensor Offset** provides compensation for temperature differences between actual and displayed temperature, such as when using long sensor leads. See Table 1 to determine the temperature value to compensate for long sensor lead extensions.

**Un Temperature Units Used** allows selection of Fahrenheit or Celsius temperature scale.

**PU Display Refresh Rate** establishes the time delay (seconds) between updates of the temperature display.

### Alarm Management Functions

**AH High Temperature Alarm** establishes the temperature relative to Setpoint (F° or C°) at which the control goes into a high temperature alarm condition. (The temperature value is added to the Setpoint.)

**AL Low Temperature Alarm** establishes the temperature relative to Setpoint (F° or C°) at which the control goes into a low temperature alarm condition. (The temperature value is subtracted from the Setpoint.)

**AH, AL High and Low Temperature Alarms** are disabled during defrost and for 20 minutes after the defrost cycle. These alarms are also disabled for 20 minutes after startup.

**Ad Alarm Differential** establishes the difference (F° or C°) between the alarm activation temperature and the alarm deactivation temperature.

Alarm Differential Example:

Setpoint = 40°F

**High Temperature Alarm** = 15F°

**Alarm Differential** = 2F°

When the temperature exceeds  $40 + 15 = 55^{\circ}\text{F}$  for a time greater than the **alarm time delay** setting, the alarm message is displayed; however, it resets after the temperature drops below  $40 + 15 - 2 = 53^{\circ}\text{F}$ .

**At Alarm Time Delay** establishes the time delay (minutes) between detecting a high or low temperature alarm condition and displaying an alarm message. This function reduces nuisance alarms caused by temperatures that temporarily exceed alarm setpoint values.

**Defrost Cycle Management Functions**

**dF Defrost Mode** allows the user to select electric heater defrost or hot gas defrost. See Table 2.

**Table 2: Defrost Mode Options**

	Defrost Mode	
	Electric Heater	Hot Gas
<b>Compressor Relay Contacts</b>	open	closed
<b>Defrost Control Relay Contacts</b>	closed	closed
<b>Defrost Device Controlled</b>	electric defrost heater	electric solenoid on hot gas bypass valve

**dE Defrost Termination Mode** allows selection of time-based or temperature-based defrost termination. Maximum Defrost Duration controls time-based defrost termination. Defrost Termination Temperature controls temperature-based defrost termination.

**dt Defrost Termination Temperature** establishes the temperature setpoint (F° or C°) that ends the defrost cycle, if temperature-based defrost termination is selected.

**di Defrost Interval** establishes the time (hours) between defrost cycles. When the Defrost Interval is 1 hour, the Maximum Defrost Duration can not exceed 40 minutes.

**dd Maximum Defrost Duration** establishes the maximum time (minutes) of the defrost cycle, if time-based defrost termination is selected. A setting of 0 disables the defrost cycle.

**dC Dripping Time** establishes the delay time (minutes) after defrost termination (and before the compressor starts for the next freeze cycle) to allow water to drain away from the evaporator coil.

**dU First Defrost Delay** establishes the time delay (hours) until the first defrost cycle after starting or restarting the refrigeration system.

This setting can allow the system to reach operating temperature before the defrost cycle is initiated.

Setting First Defrost Delay to OFF causes the first defrost after power-on to occur after the Defrost Interval has elapsed.

**dP Display During Defrost** establishes the temperature value displayed during the defrost cycle. The user may select either the Setpoint value or the temperature sensed just prior to starting the defrost cycle.

**dr Display Delay After Defrost** establishes the time delay (minutes) after defrost termination, before the control displays the sensed temperature.

**Evaporator Fan Management Functions**

**FF Fan Operating Mode** establishes when the evaporator fan operates: continuously or only when the compressor is running. Fan operation during defrost cycle depends on application wiring.

**Fd Fan Start-Up Delay** establishes the maximum time delay (minutes) after the end of the defrost cycle, before the evaporator fan restarts. The evaporator fan restarts after this time delay, even if Fan Start Temperature has not been reached.

**Fr Fan Start Temperature** establishes the temperature setpoint (F° or C°) at which the evaporator fan restarts after defrost termination.

**Binary Input Functions**

**iF Binary Input Mode** establishes how the compressor, defrost, and evaporator fan relays respond when the Binary Input Circuit is closed. See Table 3.

**Table 3: System Response to Binary Input Signal**

System Component	Binary Input Function Option Selected			
	0	1	2	3
<b>Compressor</b>	--	Off	On	On
<b>Defrost</b>	--	Off	No Change	No Change
<b>Evaporator Fan</b>	--	Off	On	Off

**id Binary Input Time Delay** establishes the time delay (minutes) between when the binary input circuit closes and the response of selected relays (compressor, defrost, and evaporator fan) initiates.

**Table 4: Function Settings in Order of Programming in Control Module**

Display Code	Function	Useable Setting Range and Unit Value	Factory-Set Values
(None)	Setpoint	-40 to 99°F (-40 to 80°C)	
HY	Differential	1 to 9F° (1 to 9C°)	5 (F°)
LL	Low Setpoint Stop	-40°F (-40°C) to High Setpoint Stop	-25 (°F)
HL	High Setpoint Stop	Low Setpoint Stop to 99°F (80°C)	40 (°F)
CC	Cycle Delay	0 to 9 minutes	1 (minutes)
Co	Deep Freezing Time	0 to 99 minutes	60 (minutes)
AH	High Temperature Alarm	0 to 50F° (0 to 50C°)	10 (F°)
AL	Low Temperature Alarm	-50 to 0F° (-50 to 0C°)	-10 (F°)
Ad	Alarm Differential	1 to 9F° (1 to 9C°)	5 (F°)
At	Alarm Time Delay	0 to 99 minutes	3 (minutes)
dF	Defrost Mode	0 = electric defrost 1 = hot gas defrost	0 (electric defrost)
dE	Defrost Termination Mode	0 = time-based 1 = temperature-based	1 (temperature-based)
dt	Defrost Termination Temperature	32 to 68°F (0 to 20°C)	55 (°F)
di	Defrost Interval	1 to 99 hours	7 (hours)
dd	Maximum Defrost Duration	0 to 99 minutes	45 (minutes)
dC	Dripping Time	0 to 99 minutes	5 (minutes)
dU	First Defrost Delay	OF, 0 to 99 minutes	OF (Off)
dP	Display During Defrost	0 = last main sensor reading 1 = main setpoint	0 (last main sensor reading)
dr	Display Delay After Defrost	1 to 99 minutes	20 (minutes)
iF	Binary Input Mode	0 = no response 1 = compressor off, alarm on 2 = alarm on 3 = evap. fan off, alarm on	0 (no response)
id	Binary Input Time Delay	0 to 99 minutes	0 (minutes)
FF	Fan Operating Mode	0 = parallel with compressor 1 = always on	0 (parallel with compressor)
Fd	Fan Startup Delay	0 to 99 minutes	5 (minutes)
Fr	Fan Start Temperature	-22 to 41°F (-30 to 5°C)	40 (°F)
SF	Sensor Failure Operation	0 = compressor on 1 = compressor off 2 = based on last four cycles	2 (based on last four cycles)
So	Temperature Sensor Offset	-20 to 20F° (-20 to 20C°)	0 (F°)
Un	Temperature Units Used	0 = °C 1 = °F	1 (°F)
PU	Display Refresh Rate	1 to 99 seconds	1 (second)

## Alarm and Fault Display Codes

These alarm and fault codes flash on the LED display when the control detects the following faults.

**Table 5: Display Codes and Status**

Display Code	Alarm or Fault Condition	System Status
<b>F1</b>	Indicates an open or shorted main temperature sensor.	Alarm is on. Compressor runs according to the Sensor Failure Mode selected. Correct problem with sensor and cycle power to reset control.
<b>F2</b>	Indicates an open or shorted evaporator temperature sensor.	Alarm is on. Defrost cycle is controlled by Defrost Interval and Defrost Duration. Correct problem with sensor to reset control.
<b>A1</b>	Binary input is open for longer than the Binary Input Time Delay and Binary Input Mode Option 1 is selected.	Alarm is on. Compressor, Defrost, and Evaporator Fan are off.
<b>A2</b>	Binary input is open for longer than Binary Input Time Delay and Binary Input Mode Option 2 is selected.	Alarm, Compressor and Evaporator Fan are on. Defrost may be on or off.
<b>A3</b>	Binary input is open for longer than the Binary Input Time Delay and Binary Input Mode Option 3 selected.	Alarm and Compressor are on. Evaporator Fan is off. Defrost may be on or off.
<b>HI</b>	Main sensor temperature has reached or exceeded the High Temperature Alarm value.	Alarm is on. Correct problem to reset control.
<b>LO</b>	Main sensor temperature has reached or fallen below the Low Temperature Alarm value.	Alarm is on. Correct problem to reset control.
<b>EE</b>	Indicates program failure.	Alarm is on. Other outputs are off. Replace control.

## Ordering Information

**Table 6: Ordering Information**

Item Code	Description	Shipping Weight
<b>MR4PMUHV-12C</b>	Relay pack temperature/defrost control with two A99B sensors	2.9 lb (1320 g)
<b>MR4PM12C-12C</b>	Replacement control module for use in relay pack only	1.6 lb (726 g)
<b>RP4MRUHV-1C</b>	Relay pack without control module	2.3 lb (1060 g)
<b>A99BB-200C</b>	Sensor, cable length: 6-1/2 ft (2 m)	0.13 lb (60 g)

## Repair and Replacement

Field repair of the control should not be made. In case of a defective or improperly functioning control, please contact your nearest Johnson Controls/PENN™ representative.

## Relay Electrical Ratings

Relay Ratings in Tables 7-9 are for ambient temperatures in the range -40 to 111°F (-40 to 44°C). Derate electrical ratings 3.45% per 1F° in the range 111 to 140°F. Derate electrical ratings 6.25% per 1C° in the range 44 to 60°C.

**Table 7: Fan Relay Single-Pole, Double-Throw (SPDT) Electrical Ratings**

	Single-Phase Ratings			
	24 VAC	120 VAC	208 VAC	240 VAC
Horsepower Rating		1/3	1/2	3/4
AC Full Load Ampere		7.2	5.65	6.9
AC Locked Rotor Ampere		43.2	33.9	41.4
Pilot Duty (VA)	50	325	450	600

**Table 8: Defrost Heater and Compressor Relay Single-Pole, Single-Throw (SPST) Electrical Ratings**

	Single-Phase Ratings			
	24 VAC	120 VAC	208 VAC	240 VAC
Horsepower Rating		1	1.5	2
AC Full Load Ampere		16	11	12
AC Locked Rotor Ampere		96	66	72
Noninductive Load Ampere (Defrost Heater Only)		20	20	20
Pilot Duty (VA)	125	750	825	1125

**Table 9: Alarm Relay (SPST) Electrical Ratings**

	Single-Phase Ratings			
	24 VAC	120 VAC	208 VAC	240 VAC
Noninductive Load Ampere	5	5	5	5
Pilot Duty (VA)		125	250	325

## Technical Specifications

<b>Product</b>	MR4PMUHV-12C Temperature/Defrost Control
<b>Relay Electrical Ratings</b>	See Tables 7-9.
<b>Frequency</b>	60 Hz
<b>Power Requirements</b>	120/240 VAC $\pm$ 10%
<b>Maximum Power Consumption</b>	10 VA @120/240 VAC
<b>Accuracy</b>	$\pm$ 1.8F° ( $\pm$ 1C°)
<b>Sensor Input Range</b>	-40 to 158°F (-40 to 70°C)
<b>A99B Sensor Cable</b>	6-1/2 ft (2 m)
<b>Ambient Operating Conditions</b>	MR4PMUHV-12C*: 14 to 111°F (-10 to 44°C); 0 to 95 % RH (noncondensing)
	MR4PM12C-12C: 14 to 140°F (-10 to 60°C); 0 to 95 % RH (noncondensing)
	RP4MRUHV-1C*: -40 to 111°F (-40 to 44°C); 0 to 95 % RH (noncondensing)
<b>Ambient Storage Conditions</b>	MR4PMUHV-12C: -22 to 176°F (-30 to 80°C) 0 to 95 % RH (noncondensing)
	MR4PM12C-12C: -22 to 176°F (-30 to 80°C) 0 to 95 % RH (noncondensing)
	RP4MRUHV-1C: -40 to 185°F (-40 to 85°C) 0 to 95 % RH (noncondensing)
<b>Dimensions (H x W x D)</b>	See Figures 3-5.
<b>Agency Listings</b>	UL Listed (US), File SA516, CCN SDFY UL Listed (Canada), File SA516, CCN SDFY7
<b>Emissions Compliance</b>	FCC (US) DOC (Canada)
<b>Shipping Weight</b>	See Table 6.

\* See Relay Electrical Ratings.

The performance specifications are nominal and conform to acceptable industry standards. For application at conditions beyond these specifications, consult Johnson Controls/Penn Application Engineering at 1-800-275-5676. Johnson Controls, Inc. shall not be liable for damages resulting from misapplication or misuse of its products.



**Controls Group**  
507 E. Michigan Street  
P.O. Box 423  
Milwaukee, WI 53201

Printed in U.S.A.  
www.johnsoncontrols.com