

**INSTALLATION BULLETIN**

**MR2 Refrigeration Temperature/Defrost Control**

**IMPORTANT:** All MR2 controls are designed for use only as operating controls. Where an operating control failure would result in personal injury or loss of property, it is the responsibility of the installer to add devices (safety, limit controls) or systems (alarm, supervisory systems) that protect against, or warn of, control failure.

Follow these wiring guidelines:

- All wiring must conform to the National Electric Code and local regulations.
- Make all wiring connections using adequate gauge copper conductors only. Connectors are rated for 14-22 AWG wiring.

Refer to the *MR Series Refrigeration Temperature Controls Product Bulletin, LIT-125199*, for necessary information on operation and performance specifications for this product.

**Mounting**

The MR2 Control is not position-sensitive but should be mounted for convenient wiring and adjustment.

To mount the Panel Mount version, ensure that there is a space of at least 2-3/4 in. (70 mm) behind the panel. Make a cutout 1-3/16 x 2-13/16 in. (29 x 71 mm). Remove retaining clip from the control. Insert the control into the hole. Install retaining clip and adjust for tightness.

To mount the DIN Rail Mount version, install the DIN rail where appropriate. Snap the control onto the rail in position.

**Wiring**

**WARNING: Shock Hazard.** To avoid possible electrical shock or equipment damage, disconnect power supply before wiring any connections.

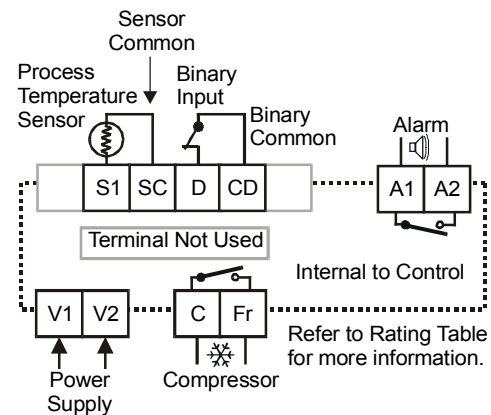

**Figure 1: MR2 DIN Rail Control**

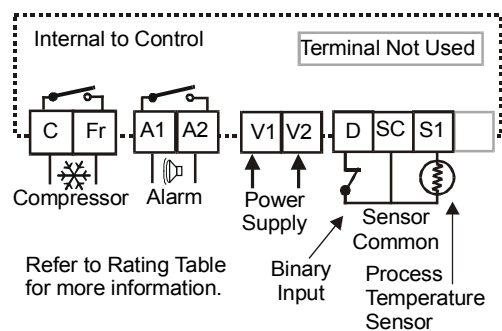

**Figure 2: MR2 Panel Mount Control**

**Canadian DOC Compliance**

This digital apparatus does not exceed the Class A limits for radio noise emissions from digital apparatus set out in the Radio Interference Regulations of the Canadian Department of Communications.

Use Table 1 with function So to compensate for long sensor leads.

**Table 1: Sensor Wire Size and Length**

18 AWG	20 AWG	22 AWG	Offset
300-599 ft 91-183 m	190-374 ft 58-114 m	120 -239 ft 36-73 m	1F° 1C°
600-899 ft 183-274 m	375-564 ft 114-172 m	240-349 ft 73-107 m	2F° 2C°
900+ ft 274+ m	565+ ft 172+ m	350+ ft 107+ m	3F° 3C°

**Table 2: Rating Table**

Rating Category	120 VAC	240 VAC	24 VDC
Horsepower	1/4	1/2	---
Full Load Amperes	5.8	4.9	---
Locked Rotor Amperes	34.8	29.4	---
Inductive (non-motor) Amperes	8	8	8
Pilot Duty VA	275	450	---

Power source is 24 VAC. Alarms require external power source.

## FCC Compliance

This equipment has been tested and found to comply with the limits for a Class A digital device pursuant to Part 15 of the FCC Rules. These limits are designed to provide reasonable protection against harmful interference when the equipment is operated in a commercial environment. This equipment generates, uses, and can radiate radio frequency energy and, if not installed and used in accordance with the instruction manual, may cause harmful interference to radio communications. Operation of this equipment in a residential area is likely to cause harmful interference, in which case the user will be required to correct the interference at his/her own expense.

## Display

Press Up and Down buttons to scroll through process temperature, binary input status (On or OF), and auxiliary temperature sensor reading (F2 if none). After 15 seconds of inactivity, the display shows the process temperature.

## Programming the Control

### To lock and unlock the unit for programming:

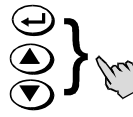

Press the Enter, Up, and Down buttons simultaneously and hold until "--" is displayed. Hold for about 10 seconds until the current temperature is displayed.

### To change the setpoint:



1. Hold the Enter button for approximately 3 seconds. The display will change to show the setpoint. Release the Enter button.



2. Press the Up or Down button until you reach the new setpoint.



3. Press the Enter button to save the new setpoint.

Note: If the Enter button is not pressed after selecting the new setpoint, the new setpoint is not saved. The control reverts to the original setpoint.

### To run the self-test procedure:

**IMPORTANT:**

Disconnect loads before self-test procedure. Cycle power to resume normal operation.

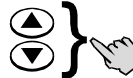

Press the Up and Down buttons in sequence, and hold for 5 seconds.

### To begin a manual defrost cycle:



Hold the Defrost button for 3 seconds.

### To begin a deep freeze cycle:



Press the Enter and Up buttons in sequence and hold both for 5 seconds. The compressor status LED will light.

### To program values other than setpoint:



1. Hold the Enter button for about 10 seconds. The display changes to HY.



2. Press the Up or Down button until the desired parameter is displayed.



3. Press the Enter button. The parameter's current value is displayed.



4. Press the Up or Down button until the desired value is shown.



5. Press the Enter button to save the new value. After 10 seconds of inactivity, the display will return to its normal function.

Note: If the Enter button is not pressed after selecting the new value, the new value is not saved. The control reverts to the previous value.

**Table 3: Functions and Settings**

Function	Description	Setting Range	Default
<b>Sl: Setpoint</b>	Primary temperature setpoint at which compressor control contacts open on temperature fall	-40 to 158°F (-40 to 70°C)	---
<b>HY: Hysteresis (Differential)</b>	Temperature difference relative to setpoint at which compressor control contacts close on temperature rise	1 to 9 F° (1 to 9 C°)	5
<b>LL: Low Setpoint Stop</b>	Low setpoint adjustment limit	-40°F (-40°C) to HL	-25
<b>HL: High Setpoint Stop</b>	High setpoint adjustment limit	LL to 158 F° (158 C°)	40
<b>CC: Anti-short Cycle Delay</b>	Minimum time between two compressor On cycles	0 to 9 minutes	1
<b>Co: Deep Freezing Time</b>	Time compressor forced On during deep freeze	0 to 99 minutes	60
<b>AH: High Temperature Alarm</b>	Temperature above setpoint where alarm is initiated	0 to 50 F° (0 to 50 C°)	10
<b>AL: Low Temperature Alarm</b>	Temperature below setpoint where alarm is initiated	-50 to 0 F° (-50 to 0 C°)	-10
<b>Ad: Alarm Differential</b>	Temperature difference between alarm On and Off	1 to 9 F° (1 to 9 C°)	5
<b>At: Alarm Time Delay</b>	Delay between alarm detection and activation	0 to 99 minutes	3
<b>di: Defrost Interval</b>	Time between two subsequent defrost cycles; when di=1 hour, dd cannot exceed 40 minutes	1 to 99 hours	7
<b>dd: Maximum Defrost Duration</b>	Defrost ends after this time; 0 disables defrost	0 to 99 minutes	45
<b>dC: Dripping Time</b>	Time compressor stopped after defrost so evaporator can drip	0 to 99 minutes	5
<b>dU: First Defrost After Power Up</b>	Time first defrost cycle is delayed after power up	OF, 0 to 99 minutes	OF (Off)
<b>dP: Display During Defrost</b>	Temperature displayed during defrost cycle	0 = last reading 1 = setpoint	0
<b>dr: Display Delay After Defrost</b>	Time after defrost before sensed temperature displays	1 to 99 minutes	20
<b>iF: Binary Input Function</b>	Configuration for normally closed binary input	0 = none 1 = compressor off, alarm on 2 = alarm on 3 = alarm on, AH and AL disabled.	0
<b>id: Binary Input Time Delay</b>	Time between binary input detection and enabling of the function set through iF	0 to 99 minutes	0
<b>SF: Sensor Failure Operation</b>	Control function after a sensor or sensor wire failure	0 = compressor On 1 = compressor Off 2 = based on last four cycles	2
<b>So: Temperature Sensor Offset</b>	Compensate for long sensor leads	-20 to 20 F° (-20 to 20 C°)	0
<b>Un: Temperature Units Used</b>	Temperature units used	0 = °C      1 = °F	1
<b>PU: Display Refresh Rate</b>	Time after which display is refreshed	1 to 99 seconds	1

## Repair and Replacement

Field repair of the control should not be made. In case of a defective or improperly functioning control, check with your nearest Johnson Controls/PENN representative.

When contacting the supplier for replacement, state the model number of the control. This number can be found on the data plate.

**Table 4: Error Codes and Status**

Error Code (Codes will flash on the display)	System Status
F1 Open or shorted temperature sensor	Alarm output On. Compressor runs according to SF. Cycle power to reset.
A1 Binary input open for longer than id and iF = 1	Compressor output Off. Alarm output On. Correct problem to reset.
A2 Binary input open for longer than id and iF = 2	Alarm output On. Correct problem to reset.
A3 Binary input open for longer than id and iF = 3	Alarm output On, AH and AL disabled. Correct problem to reset.
HI Temperature has reached or exceeded (setpoint + AH)	Alarm output On. Correct problem to reset.
LO Temperature has reached or fallen below (setpoint – AL)	Alarm output On. Correct problem to reset.
EE Program failure	Alarm output On. Other outputs Off. Replace control.

## Ordering Information

**Table 5: Specifications**

<b>Power Requirements</b>	3.7 VA @ 24 VAC 50/60 Hz, Class 2 (20-30 VAC)
<b>Ambient Conditions</b>	Operating 14 to 140°F (-10 to 60°C); 0 to 95% RH (non-condensing) Storage -22 to 176°F (-30 to 80°C); 0 to 95% RH (non-condensing)
<b>Accuracy</b>	±1.8 F° (±1C°)
<b>Agency Listings</b>	UL Recognized: File E194024, CCN XAPX2 Canadian UL Recognized: File E194024, CCN XAPX8 FCC Compliant per Class A Digital Device, Part 15 Canadian DOC Compliant per Class A, Radio Interference Regulations

**Table 6: Ordering Information**

Product Code Number	Description
<b>MR2PM24-11C</b>	MR2 Panel Mount Control; A99BB-200C sensor included
<b>MR2DR24-11C</b>	MR2 DIN Rail Mount Control; A99BB-200C sensor included
<b>A99BB-200C</b>	Replacement Sensor, cable length: 6-1/2 ft (2 m)

*The performance specifications are nominal and conform to acceptable industry standards. For application at conditions beyond these specifications, consult Johnson Controls/Penn Refrigeration Application Engineering at (414) 274-5535. Johnson Controls, Inc. shall not be liable for damages resulting from misapplication or misuse of its products.*



**Controls Group**  
507 E. Michigan Street  
P.O. Box 423  
Milwaukee, WI 53201

Printed in U.S.A.  
www.johnsoncontrols.com