

INSTALLATION BULLETIN

MR1 Refrigeration Temperature Control

IMPORTANT: All MR1 controls are designed for use only as operating controls. Where an operating control failure would result in personal injury or loss of property, it is the responsibility of the installer to add devices (safety, limit controls) or systems (alarm, supervisory systems) that protect against, or warn of, control failure.

Refer to the *MR Series Refrigeration Temperature Controls Product Bulletin, LIT-125199*, for necessary information on application, operation and performance specifications for this product.

Mounting

The MR1 control is not position sensitive but should be mounted for convenient wiring and adjustment. To mount the DIN Rail Mount version, install the DIN rail where appropriate. Snap the control onto the rail in position.

Wiring

WARNING: **Shock Hazard.** To avoid possible electrical shock or damage to equipment, disconnect power supply before wiring any connections.

- Follow these wiring guidelines:
- All wiring must conform to the National Electric Code and local regulations.
 - Make all wiring connections using adequate gauge copper conductors only. Connectors are rated for 14-22 AWG wiring.

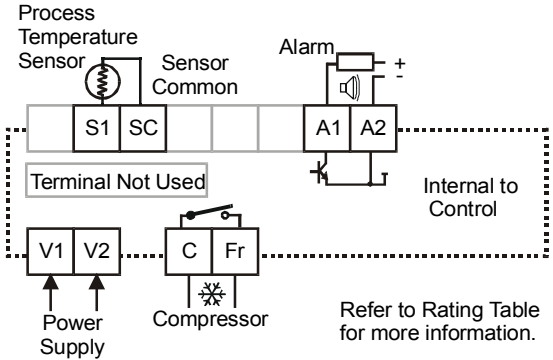

Figure 1: MR1 DIN Rail Mount Control

Use Table 1 with function So to compensate for long sensor leads.

Table 1: Sensor Wire Size and Length

Wire Size and Cable Length			Offset
18 AWG	20 AWG	22 AWG	
300-599 ft 91-183 m	190-374 ft 58-114 m	120 -239 ft 36-73 m	1F° 1C°
600-899 ft 183-274 m	375-564 ft 114-172 m	240-349 ft 73-107 m	2F° 2C°
900+ ft 274+ m	565+ ft 172+ m	350+ ft 107+ m	3F° 3C°

Table 2: Rating Table

Rating Category	120 VAC	240 VAC	24 VDC
Horsepower	1/4	1/2	---
Full Load Amperes	5.8	4.9	---
Locked Rotor Amperes	34.8	29.4	---
Inductive (non-motor) Amperes	8	8	8
Pilot Duty VA	275	450	---

Open collector transistors on MR1 alarms have a maximum rating of 40 VDC 100 mA. Alarms require separate power source. Power source is 24 VAC.

FCC Compliance

This equipment has been tested and found to comply with the limits for a Class A digital device pursuant to Part 15 of the FCC Rules. These limits are designed to provide reasonable protection against harmful interference when the equipment is operating in a commercial environment. This equipment generates, uses, and can radiate radio frequency energy and, if not installed and used in accordance with the instruction manual, may cause harmful interference to radio communications. Operation of this equipment in a residential area is likely to cause harmful interference, in which case the user will be required to correct the interference at his/her own expense.

Canadian DOC Compliance

This digital apparatus does not exceed the Class A limits for radio noise emissions from digital apparatus set out in the Radio Interference Regulations of the Canadian Department of Communications.

Programming the Control

To lock and unlock the unit for programming:

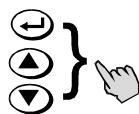

Press the Enter, Up, and Down buttons simultaneously and hold until “- - -” is displayed. Hold for about 10 seconds until the current temperature is displayed.

To change the setpoint:



1. Hold the Enter button for approximately 3 seconds. The display will change to show the setpoint. Release the Enter button.



2. Press the Up or Down button until you reach the new setpoint.



3. Press the Enter button to save the new setpoint.

Note: If the Enter button is not pressed after selecting the new setpoint, the new setpoint is not saved. The control reverts to the original setpoint.

To run the self-test procedure:

IMPORTANT:

Disconnect loads before self-test procedure. Cycle power to resume normal operation.



Press the Up and Down buttons in sequence, and hold for 5 seconds.

To begin a deep freeze cycle:



Press the Enter and Up buttons in sequence and hold both for 5 seconds. The compressor status LED will light.

To program values other than setpoint:



1. Hold the Enter button for about 10 seconds. The display changes to HY.



2. Press the Up or Down button until the desired parameter is displayed.



3. Press the Enter button. The parameter's current value is displayed.



4. Press the Up or Down button until the desired value is shown.



5. Press the Enter button to save the new value. After 10 seconds of inactivity, the display will return to its normal function.

Note: If the Enter button is not pressed after selecting the new value, the new value is not saved. The control reverts to the previous value.

Table 3: Functions and Settings

Function	Description	Setting Range	Default
Sl: Setpoint	Primary temperature setpoint at which compressor control contacts open on temperature fall	-40 to 158°F (-40 to 70°C)	---
HY: Hysteresis (Differential)	Temperature difference relative to setpoint at which compressor control contacts close on temperature rise	1 to 9 F°(1 to 9 C°)	5
LL: Low Setpoint Stop	Low setpoint adjustment limit	-40°F(-40°C) to HL	-25
HL: High Setpoint Stop	High setpoint adjustment limit	LL to 158°F (70°C)	40
CC: Anti-Short Cycle Delay	Minimum time between two compressor On cycles	0 to 9 minutes	1
Co: Deep Freezing Time	Time compressor forced On during deep freeze	0 to 99 minutes	60
AH: High Temperature Alarm	Temperature above setpoint where alarm is initiated	0 to 50 F°(0 to 50 C°)	10
AL: Low Temperature Alarm	Temperature below setpoint where alarm is initiated	-50 to 0 F°(-50 to 0 C°)	-10
Ad: Alarm Differential	Temperature difference between alarm On and Off	1 to 9 F°(1 to 9 C°)	5
At: Alarm Time Delay	Delay between alarm detection and activation	0 to 99 minutes	3
SF: Sensor Failure Operation	Control function after a temperature sensor failure	0 = compressor on 1 = compressor off 2 = based on last four cycles	2
So: Temperature Sensor Offset	Compensate for long sensor leads	-20 to 20 F°(-20 to 20 C°)	0
Un: Temperature Units Used	Temperature units used	0 = °C 1 = °F	1
PU: Display Refresh Rate	Time after which display is refreshed	1 to 99 seconds	1

Repair and Replacement

Field repair must not be made. In case of defective or improperly functioning control, contact your nearest authorized Johnson Controls/PENN distributor.

When requesting a replacement, reference the model number found on the data plate of the control.

Alarm and Fault Codes

Table 4: Error Codes and Status

Error Code (Codes will flash on the display.)	System Status
F1 Open or shorted temperature sensor	Alarm output On. Compressor runs according to SF. Cycle power to reset.
HI Temperature has reached or exceeded (setpoint + AH)	Alarm output On. Correct problem to reset.
LO Temperature has reached or fallen below (setpoint – AL)	Alarm output On. Correct problem to reset.
EE Program failure	Alarm output On. Other outputs Off. Replace control.

Ordering Information

Table 5: Specifications

Power Requirements	3.7 VA @ 24 VAC, 50/60 Hz, Class 2 (20-30 VAC)
Ambient Conditions	Operating 14 to 140°F (-10 to 60°C); 0 to 95% RH (non-condensing) Storage -22 to 176°F (-30 to 80°C); 0 to 95% RH (non-condensing)
Accuracy	±1.8 F° (±1 C°)
Agency Listings	UL Recognized: File E194024, CCN XAPX2 Canadian UL Recognized: File E194024, CCN XAPX8 FCC Compliant per Class A Digital Device, Part 15 Canadian DOC Compliant per Class A, Radio Interference Regulations

Table 6: Ordering Information

Product Code Number	Description
MR1DR24-11C	MR1 DIN Rail Mount Control; A99BB-200C sensor included
A99BB-200C	Replacement Sensor, cable length: 6-1/2 ft (2 m)

The performance specifications are nominal and conform to acceptable industry standards. For application at conditions beyond these specifications, consult Johnson Controls/Penn Refrigeration Application Engineering at (414) 274-5535. Johnson Controls, Inc. shall not be liable for damages resulting from misapplication or misuse of its products.



Controls Group
507 E. Michigan Street
P.O. Box 423
Milwaukee, WI 53201

Printed in U.S.A.
www.johnsoncontrols.com