

# Vertical Wallbox-Mounted or Surface-Mounted NS Series Network Sensors with LCD

## Installation Instructions

Part No. 24-10094-25, Rev. H

Issued December 16, 2011

Supersedes August 1, 2011

NS-BHB700x-0, NS-BHR710x-0, NS-BPB700x-0,  
NS-BTB700x-x, NS-BTF700x-0, NS-BTV700x-0

Refer to the [QuickLIT Web site](#) for the most up-to-date version of this document.

### Applications

The vertical wallbox-mounted or surface-mounted NS Series Network Sensor with Liquid Crystal Display (LCD) is an electronic zone sensor designed to function directly with Johnson Controls® BACnet® Master-Slave/Token-Passing (MS/TP) digital controllers in Heating, Ventilating, and Air Conditioning (HVAC) systems. Models in this series monitor the temperature setpoint, zone temperature, and humidity, and transmit this data to a field controller on the Sensor Actuator (SA) Bus.

All models feature a temperature setpoint dial and LCD designed to make adjusting the temperature setpoint and viewing the zone temperature easier. A warmer/cooler dial is included on certain models for minor temperature adjustments from the setpoint.

Some models also allow occupants to view the Relative Humidity (RH) of the zone; these models include a push button to toggle between temperature and RH on the display. These models also have the capability to set the desired default display to either temperature or RH.

A °F/°C push button is available on all models to provide temperature scale options for display. An occupancy override function is featured on all models, which allows the user to signal the controller that the space is occupied, to request an override of time-of-day scheduling. Rotating the setpoint dial signals occupancy. See [Temperature Setpoint Adjustment/Occupancy Override](#) for more information.

Select models in this series also provide Variable Air Volume (VAV) balancing functionality. These models look like and perform similarly to the other network sensors but have the added capability of serving as a tool to balance a VAV box.

Depending on the model chosen, the wires connecting the network sensor to the controller can be terminated using either a modular jack or screw terminal block, offering wiring flexibility.

**Note:** Models featuring a modular jack are not intended for installations where daisy chaining to the MS/TP Bus is required.

All models include an SA Bus access port for connecting accessories to access the SA Bus. This feature allows a technician to commission or service the controller via the network sensor.

**IMPORTANT:** The NS Series Network Sensor is intended to provide an input to equipment under normal operating conditions. Where failure or malfunction of the network sensor could lead to personal injury or property damage to the controlled equipment or other property, additional precautions must be designed into the control system. Incorporate and maintain other devices, such as supervisory or alarm systems or safety or limit controls, intended to warn of or protect against failure or malfunction of the network sensor.

## North American Emissions Compliance

### United States

This equipment has been tested and found to comply with the limits for a Class A digital device pursuant to Part 15 of the FCC Rules. These limits are designed to provide reasonable protection against harmful interference when this equipment is operated in a commercial environment. This equipment generates, uses, and can radiate radio frequency energy and, if not installed and used in accordance with the instruction manual, may cause harmful interference to radio communications. Operation of this equipment in a residential area is likely to cause harmful interference, in which case the user will be required to correct the interference at his/her own expense.

### Canada

This Class (A) digital apparatus meets all the requirements of the Canadian Interference-Causing Equipment Regulations.

Cet appareil numérique de la Classe (A) respecte toutes les exigences du Règlement sur le matériel brouilleur du Canada.

## Installation

### Special Tools Needed

A 1/16 in. (1.5 mm) Allen wrench or a Johnson Controls T-4000-119 Allen-Head Adjustment Tool is required during installation.

### Mounting

**Note:** For wallbox-mounted installations, the NS Series Network Sensor is intended to be mounted on a vertically roughed-in wallbox only; do not attempt to mount the network sensor on a horizontally roughed-in wallbox.

### Location Considerations

Locate the network sensor:

- on a partitioning wall, approximately 5 ft (1.5 m) above the floor in a location of average temperature
- away from direct sunlight, radiant heat, outside walls, outside doors, air discharge grills, or stairwells; and from behind doors
- away from steam or water pipes, warm air stacks, unconditioned areas (not heated or cooled), or sources of electrical interference

**Note:** The network sensor is shock and vibration resistant; however, be careful not to drop the unit or mount it where it could be exposed to excessive vibration.

The following ambient operating conditions apply:

- Temperature: 32 to 104°F (0 to 40°C)
- Humidity: 10 to 90% Relative Humidity (RH), noncondensing; 85°F (29°C) maximum dew point

To mount the network sensor:

1. Use a 1/16 in. (1.5 mm) Allen wrench or Johnson Controls T-4000-119 Allen-Head Adjustment Tool to loosen the security screw on the top of the unit.
2. Insert a coin into the slot next to the security screw location, then carefully pry the top edge of the sensor assembly away from its mounting base and remove.

**IMPORTANT:** Do not remove the Printed Circuit Board (PCB). Removing the PCB voids the product warranty.

3. For vertical wallbox-mounted installations, proceed to Step 4. For surface-mounted installations, proceed to Step 7.
  4. Pull out approximately 6 in. (152 mm) of cable from the wallbox, and insert the cable through the hole in the mounting base.
  5. Align the mounting base on the wallbox.
- Note:** Confirm that the mounting base is positioned with the proper edge up. The mounting base is positioned properly when the security screw is located on the top edge of the base.
6. Secure the mounting base to the wallbox using the two No. 6 pan-head mounting screws included with the unit. Proceed to Step 9.
  7. Align the mounting base on the wall, and use the base as a template to mark the location of the two mounting holes on the surface.

**Note:** Confirm that the mounting base is positioned with the proper edge up. The mounting base is positioned properly when the security screw is located on the top edge of the base.

8. Secure the mounting base to the wall using the appropriate mounting hardware (field furnished). Proceed to Step 9.

- Wire the network sensor. For more details on wiring the MS/TP Communications Bus, refer to the *MS/TP Communications Bus Technical Bulletin (LIT-12011034)* or the *FX-PC Series Controllers MS/TP Communications Bus Technical Bulletin (LIT-12011670)*.

For models featuring a modular jack, simply snap the wiring plug into the jack. See Figure 1 for modular jack pin number assignments. Modular jack models require a straight-through, one-to-one connection (not a crossover). For models featuring a screw terminal block, wire the unit as illustrated in Figure 1.



**CAUTION: Risk of Electric Shock.**  
Disconnect the power supply before making electrical connections to avoid electric shock.

**IMPORTANT:** Failure to adhere to these wiring details causes the network sensor to function incorrectly. You will not be able to connect to the system using the wireless commissioning converter or the handheld VAV balancing tool, and you will not be able to expand the system with future offerings.

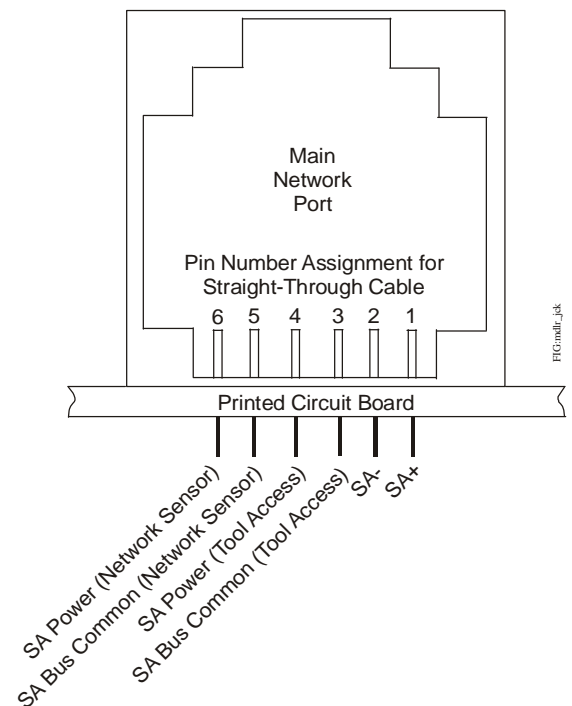

**Figure 1: Modular Jack Pin Number Assignments**

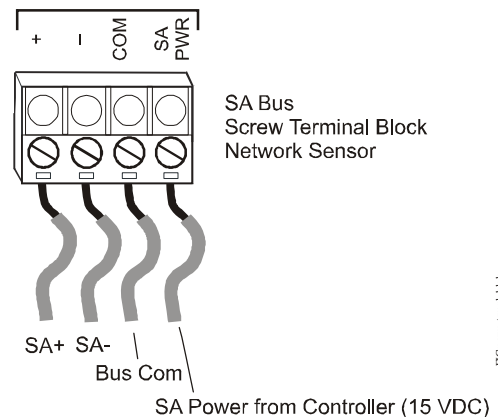

**Figure 2: Wiring to the Screw Terminal Block**

- Align the tabs on the bottom edge of the mounting base with the slots on the bottom edge of the network sensor assembly, and rotate the assembly onto its mounting base.

**Note:** On models featuring a screw terminal block, be certain that the terminal block pins align with the holes in the terminal block.

- Use a 1/16 in. (1.5 mm) Allen wrench or Johnson Controls T-4000-119 Allen-Head Adjustment Tool to tighten the security screw and fasten the network sensor assembly to the mounting base.

**Note:** Do not overtighten the security screw to avoid damaging the unit.

- Use the Metasys® Controller Configuration Tool (CCT) or Facility Explorer Programmable Controller Tool (FX-PCT) software to commission the network sensor. Refer to the Controller Tool Help (LIT-12011147) for more details.

## Setup and Adjustments

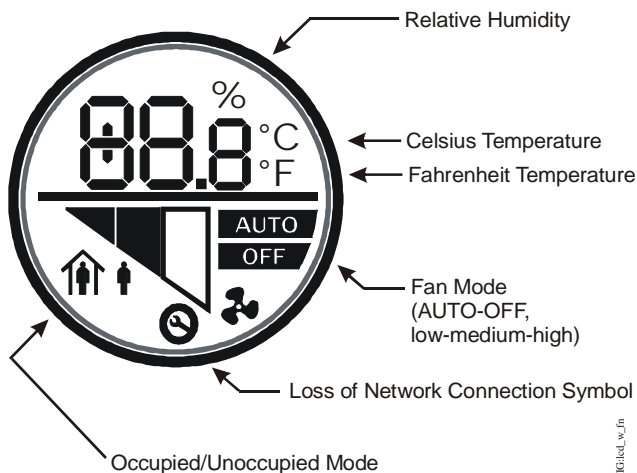

**Figure 3: LCD on Temperature/RH Models**

### Temperature Setpoint Adjustment/Occupancy Override

The large dial on the face of the network sensor functions in two ways: to increase or decrease the setpoint temperature, and to change the controller mode from unoccupied and occupied. When the dial is rotated slightly, the backlight on the LCD lights up. If the dial is rotated slightly again, and the controller is in the unoccupied mode, the controller changes from the after-normal-working-hours setback mode to the normal-working-hours comfort mode. To adjust the setpoint, continue rotating the dial until the current setpoint is displayed and flashing. Turn the dial clockwise to increase the setpoint and counterclockwise to decrease the setpoint. Stop turning the dial once the desired setpoint is reached. The new setpoint stops flashing and becomes fixed after a few seconds.

### °F/°C Temperature Mode Selection

All models include a °F/°C push button on the face of the network sensor to provide temperature scale options for display. Pressing the push button toggles the temperature mode between Fahrenheit and Celsius on the LCD.

### Temperature/RH Mode Selection

Temperature/RH models include a push button on the face of the network sensor to allow occupants to view the temperature and relative humidity of the zone. Pressing the push button toggles between temperature and RH on the LCD. The LCD defaults to temperature 5 seconds after the push button is released.

The NS-BHR710x-0 models also have the capability to set the desired default display to either temperature or RH. Follow this procedure to change the default display on these models:

- If the display backlight is off, press and release the push button to illuminate the backlight. If the display backlight is already on, proceed to Step 2.
- Press and hold the push button for 5 seconds to switch to the desired default display (either temperature or RH).

**Note:** The desired default display will flash for 5 seconds. After the display stops flashing, the new default display is in effect.

- Release the push button; the desired display is now the new default display.

### Network Sensor Addressing

Most network sensors have a default device address of 199 on the SA Bus. For the NS-BTB7003-0 averaging model, the sensor address must be set on the dual-switch DIP switch block on the network sensor Printed Wire Board (PWB).

The averaging model is shipped with both switches set to ON, resulting in a device address of 203. Device addresses can be DIP switch set from 200 to 203; see Figure 4 and Table 1 for more details.

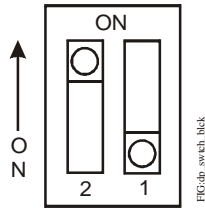

**Figure 4: Dual-Switch  
DIP Switch Block**

## Repair Information

If the NS Series Network Sensor fails to operate within its specifications, replace the unit. For a replacement network sensor, contact the nearest Johnson Controls representative.

**Table 1: Network Sensor Addressing**

DIP Switch Address	Switch 2	Switch 1
200	OFF	OFF
201	OFF	ON
202	ON	OFF
203	ON	ON

## Technical Specifications

### *Vertical Wallbox-Mounted or Surface-Mounted NS Series Network Sensors with LCD (Part 1 of 2)*

<b>Supply Voltage</b>		9.8 to 16.5 VDC; 15 VDC Nominal (From SA Bus)
<b>Current Consumption</b>	<b>Temperature Only Models</b>	21 mA Maximum (Non-transmitting)
	<b>Temperature and Humidity Models</b>	25 mA Maximum (Non-transmitting)
<b>Terminations</b>		Modular Jack or Screw Terminal Block
<b>Network Sensor Addressing</b>	<b>NS-BHx7003-0, NS-BPB7003-0, NS-BTB7003-0 Models</b>	DIP Switch Set from 200 to 203; Factory Set at 203
	<b>All Other Models</b>	Fixed Address of 199
<b>Wire Size</b>	<b>Modular Jack Models</b>	24 or 26 AWG (0.5 or 0.4 mm Diameter); Three Twisted Pair (Six Conductors)
	<b>Screw Terminal Block Models</b>	18 to 22 AWG (1.0 to 0.6 mm Diameter); 22 AWG (0.6 mm Diameter) Recommended
<b>Communication Rate</b>		Auto-Detect: 9.6k, 19.2k, 38.4k, or 76.8k bps
<b>Temperature Measurement Range</b>		32.0°F/0.0°C to 104.0°F/40.0°C
<b>Humidity Measurement Range</b>	<b>Full Range</b>	0 to 100% RH
	<b>Calibrated Range</b>	10 to 90% RH
<b>Temperature Sensor Type</b>		Local Platinum Resistance Temperature Detector (RTD)
<b>Humidity Sensor Type</b>		Thin Film Capacitive Sensor

## Vertical Wallbox-Mounted or Surface-Mounted NS Series Network Sensors with LCD (Part 2 of 2)

<b>Temperature Resolution</b>		±0.5F°/±0.5C°
<b>Temperature Sensor Accuracy</b>		±1.0F°/±0.6C°
<b>Humidity Element Accuracy</b>	<b>NS-BPB700x-0 Models</b>	±2% RH for 20 to 80% RH; ±4% RH for 10 to 20% and 80 to 90% RH
	<b>NS-BHB700x-0 Models</b>	±3% RH for 20 to 80% RH; ±6% RH for 10 to 20% and 80 to 90% RH
<b>Time Constant</b>		10 Minutes Nominal at 10 fpm Airflow
<b>Default Temperature Setpoint Adjustment Range</b>		50.0°F/10.0°C to 86.0°F/30.0°C in 0.5° Increments
<b>Ambient Conditions</b>	<b>Operating</b>	32 to 104°F (0 to 40°C); 10 to 90% RH, Noncondensing; 85°F (29°C) Maximum Dew Point
	<b>Storage</b>	-4 to 140°F (-20 to 60°C); 5 to 95% RH, Noncondensing
<b>Compliance</b>  	<b>BACnet International</b>	BACnet Testing Laboratories™ (BTL) 135-2004 Listed BACnet Smart Sensor (B-SS) <b>Note:</b> Excludes the NS-BTV700x-0 models.
	<b>United States</b>	UL Listed, File E107041, CCN PAZX, Under UL 916, Energy Management Equipment
		FCC Compliant to CFR 47, Part 15, Subpart B, Class A
	<b>Canada</b>	UL Listed, File E107041, CCN PAZX7, Under CAN/CSA C22.2 No. 205, Signal Equipment
		Industry Canada, ICES-003
	<b>Europe</b>	CE Mark – Johnson Controls, Inc., declares that this product is in compliance with the essential requirements and other relevant provisions of the EMC Directive 2004/108/EC.
<b>Australia and New Zealand</b>	C-Tick Mark, Australia/NZ Emissions Compliant	
<b>Dimensions (Height x Width x Depth)</b>		4-23/32 x 3-5/32 x 1-3/8 in. (120 x 80 x 35 mm)
<b>Shipping Weight</b>		0.25 lb (0.11 kg)

The performance specifications are nominal and conform to acceptable industry standards. For application at conditions beyond these specifications, consult the local Johnson Controls office. Johnson Controls, Inc. shall not be liable for damage resulting from misapplication or misuse of its products.



**Building Efficiency**

507 E. Michigan Street, Milwaukee, WI 53202

Metasys® and Johnson Controls® are registered trademarks of Johnson Controls, Inc.  
All other marks herein are the marks of their respective owners. © 2011 Johnson Controls, Inc.