

Wallbox-Mounted NS Series Network Sensors without LCD

Installation Instructions

NS-BHP7001-0, NS-BHN7001-0,
NS-BTN700x-x, NS-BTP700x-x

Part No. 24-10094-33, Rev. D

Release 5.0

Issued January 4, 2010

Supersedes October 6, 2008

Applications

The wallbox-mounted NS Series Network Sensor without Liquid Crystal Display (LCD) is an electronic zone sensor designed to function directly with Johnson Controls® BACnet® Master-Slave/Token-Passing (MS/TP) digital controllers in Heating, Ventilating, and Air Conditioning (HVAC) systems. Models in this series monitor the zone temperature and humidity, and transmit this data to a field controller on the Sensor Actuator (SA) Bus.

A warmer/cooler dial is included on certain models for minor temperature adjustments from the setpoint. An occupancy override button is also featured on some models, which allows the user to signal the controller that the space is occupied, to request an override of time-of-day scheduling. Select models include DIP switches to set a unique address in averaging applications. Models are available with or without a Johnson Controls logo on the face of the unit.

Depending on the model chosen, the wires connecting the network sensor to the controller can be terminated using either a modular jack or screw terminal block, offering wiring flexibility.

Note: Models featuring a modular jack are not intended for installations where daisy chaining to the MS/TP Bus is required.

All models include an SA Bus access port for connecting accessories to access the SA Bus. This feature allows a technician to commission or service the controller via the network sensor.

IMPORTANT: The wallbox-mounted NS Series Network Sensor is intended to provide an input to equipment under normal operating conditions. Where failure or malfunction of the network sensor could lead to personal injury or property damage to the controlled equipment or other property, additional precautions must be designed into the control system. Incorporate and maintain other devices, such as supervisory or alarm systems or safety or limit controls, intended to warn of or protect against failure or malfunction of the network sensor.

North American Emissions Compliance

United States

This equipment has been tested and found to comply with the limits for a Class A digital device pursuant to Part 15 of the FCC Rules. These limits are designed to provide reasonable protection against harmful interference when this equipment is operated in a commercial environment. This equipment generates, uses, and can radiate radio frequency energy and, if not installed and used in accordance with the instruction manual, may cause harmful interference to radio communications. Operation of this equipment in a residential area is likely to cause harmful interference, in which case the user will be required to correct the interference at his/her own expense.

Canada

This Class (A) digital apparatus meets all the requirements of the Canadian Interference-Causing Equipment Regulations.

Cet appareil numérique de la Classe (A) respecte toutes les exigences du Règlement sur le matériel brouilleur du Canada.

Installation

Special Tools Needed

A 1/16 in. (1.5 mm) Allen wrench or a Johnson Controls T-4000-119 Allen-Head Adjustment Tool is required during installation.

Mounting

Note: The wallbox-mounted NS Series Network Sensor is intended to be mounted on a vertically roughed-in wallbox only; do not attempt to mount the network sensor on a horizontally roughed-in wallbox.

Location Considerations

Locate the network sensor:

- on a partitioning wall, approximately 5 ft (1.5 m) above the floor in a location of average temperature

- away from direct sunlight, radiant heat, outside walls, outside doors, air discharge grills, or stairwells; and from behind doors
- away from steam or water pipes, warm air stacks, unconditioned areas (not heated or cooled), or sources of electrical interference

Note: The network sensor is shock and vibration resistant; however, be careful not to drop the unit or mount it where it could be exposed to excessive vibration.

The following ambient operating conditions apply:

- Temperature: 32 to 104°F (0 to 40°C)
- Humidity: 10 to 90% Relative Humidity (RH), noncondensing; 85°F (29°C) maximum dew point

To mount the network sensor to a wallbox:

1. Use a 1/16 in. (1.5 mm) Allen wrench or Johnson Controls T-4000-119 Allen-Head Adjustment Tool to loosen the security screw on the top of the unit.
2. Insert a blade screwdriver or coin into the slot next to the security screw location, then carefully pry the top edge of the sensor assembly away from its mounting base and remove.

IMPORTANT: Do not remove the Printed Circuit Board (PCB). Removing the PCB voids the product warranty.

3. Pull out approximately 6 in. (152 mm) of cable from the wallbox, and insert the cable through the hole in the mounting base.

4. Align the mounting base on the wallbox.

Note: Confirm that the mounting base is positioned with the proper edge up. The mounting base is positioned properly when the security screw is located on the top edge of the base.

5. Secure the mounting base to the wallbox using the two No. 6 pan-head mounting screws included with the unit.
6. Wire the network sensor. For more details on wiring the MS/TP Communications Bus, refer to the *MS/TP Communications Bus Technical Bulletin (LIT-12011034)*.

For models featuring a modular jack, simply snap the wiring plug into the jack. See Figure 1 for modular jack pin number assignments. Modular jack models require a straight-through, one-to-one connection (not a crossover). For models featuring a screw terminal block, wire the unit as illustrated in Figure 2.



CAUTION: Risk of Electric Shock.

Disconnect power supply before making electrical connections to avoid electric shock.

IMPORTANT: Failure to adhere to these wiring details causes the network sensor to function incorrectly. You will not be able to connect to the system using the wireless commissioning converter or the handheld Variable Air Volume (VAV) balancing tool, and you will not be able to expand the system with future offerings.

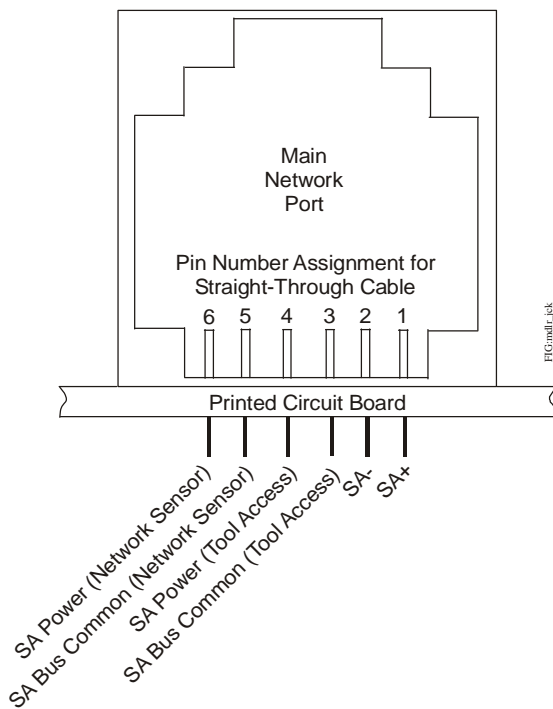

Figure 1: Modular Jack Pin Number Assignments

- Align the tabs on the bottom edge of the mounting base with the slots on the bottom edge of the network sensor assembly, and rotate the assembly onto its mounting base.

Note: On models featuring a screw terminal block, be certain that the terminal block pins align with the holes in the terminal block.

- Use a 1/16 in. (1.5 mm) Allen wrench or Johnson Controls T-4000-119 Allen-Head Adjustment Tool to tighten the security screw and fasten the network sensor assembly to the mounting base.

Note: Do not overtighten the security screw to avoid damaging the unit.

- Use the Controller Configuration Tool (CCT) software to commission the network sensor. Refer to the CCT *Help* for more details.

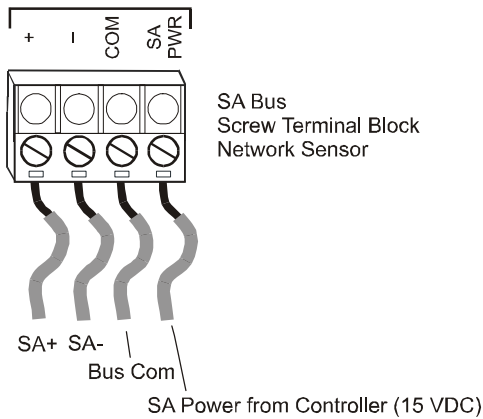

Figure 2: Wiring to the Screw Terminal Block

Setup and Adjustments

Warmer/Cooler Adjustment

Certain models include a warmer/cooler dial designed to make minor temperature adjustments from the setpoint. Turning the warmer/cooler dial adjusts the temperature setpoint up to $\pm 5.0\text{F}^\circ/\pm 3.0\text{C}^\circ$.

Occupancy Override

Some models include an occupancy override push button on the left side of the network sensor, inline with the green Light-Emitting Diode (LED). If the green LED is illuminated, the network sensor is in the occupancy override mode. If the green LED is not illuminated, pressing the occupancy override push button activates the normal-working-hours comfort mode.

Network Sensor Addressing

Most network sensors have a default device address of 199 on the SA Bus. For averaging models, the sensor address must be set on the dual-switch DIP switch block on the network sensor Printed Wire Board (PWB).

Averaging models are shipped with both switches set to ON, resulting in a device address of 203. Device addresses can be DIP switch set from 200 to 203; see Figure 3 and Table 1 for more details.

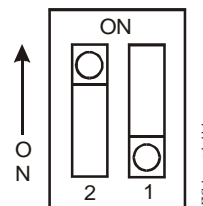

Figure 3: Dual-Switch DIP Switch Block

Table 1: Network Sensor Addressing

DIP Switch Address	Switch 2	Switch 1
200	OFF	OFF
201	OFF	ON
202	ON	OFF
203	ON	ON

Repair Information

If the NS Series Network Sensor fails to operate within its specifications, replace the unit. For a replacement network sensor, contact the nearest Johnson Controls representative.

Technical Specifications

Wallbox-Mounted NS Series Network Sensors without Setpoint Adjustment (Part 1 of 2)

Supply Voltage		9.8 to 16.5 VDC; 15 VDC Nominal (From SA Bus)
Current Consumption		13 mA Maximum (Non-transmitting)
Terminations		Modular Jack or Screw Terminal Block
Network Sensor Addressing	NS-BTx7003-0 Models	DIP Switch Set from 200 to 203; Factory Set at 203
	All Other Models	Fixed Address of 199
Wire Size	Modular Jack Models	26 AWG (0.4 mm Diameter) Recommended; Three Twisted Pair (Six Conductors)
	Screw Terminal Block Models	18 to 22 AWG (1.0 to 0.6 mm Diameter); 22 AWG (0.6 mm Diameter) Recommended
Communication Rate		Auto-Detect: 9.6k, 19.2k, 38.4k, or 76.8k bps
Temperature Measurement Range		32.0°F/0.0°C to 104.0°F/40.0°C
Humidity Measurement Range	Full Range	0 to 100% RH
	Calibrated Range	10 to 90% RH
Temperature Sensor Type		Local Platinum Resistance Temperature Detector (RTD)

Wallbox-Mounted NS Series Network Sensors without Setpoint Adjustment (Part 2 of 2)

Humidity Sensor Type		Thin Film Capacitive Sensor
Temperature Sensor Accuracy		±1.0F°/±0.6C°
Humidity Element Accuracy		±3% RH for 20 to 80% RH; ±6% RH for 10 to 20% and 80 to 90% RH
Time Constant		10 Minutes Nominal at 10 fpm Airflow
Default Temperature Setpoint Adjustment Range		±5.0F°/±3.0C°
Ambient Conditions	Operating	32 to 104°F (0 to 40°C); 10 to 90% RH, Noncondensing; 85°F (29°C) Maximum Dew Point
	Storage	-40 to 158°F (-40 to 70°C); 5 to 95% RH, Noncondensing
Compliance	BACnet International	BACnet Testing Laboratories™ (BTL) 135-2004 Listed BACnet Smart Sensor (B-SS)
	United States	UL Listed, File E107041, CCN PAZX, Under UL 916, Energy Management Equipment
		FCC Compliant to CFR 47, Part 15, Subpart B, Class A
	Canada	UL Listed, File E107041, CCN PAZX7, Under CAN/CSA C22.2 No. 205, Signal Equipment
		Industry Canada, ICES-003
	Europe	CE Mark, EMC Directive 2004/108/EC
EN61000-6-3 (2001) Generic Emission Standard for Residential and Light Industry		
EN61000-6-2 (2001) Generic Immunity Standard for Heavy Industrial Environment		
Australia and New Zealand	C-Tick Mark, Australia/NZ Emissions Compliant	
Dimensions (Height x Width x Depth)		4-23/32 x 3-5/32 x 1-3/8 in. (120 x 80 x 35 mm)
Shipping Weight		0.25 lb (0.11 kg)

The performance specifications are nominal and conform to acceptable industry standards. For application at conditions beyond these specifications, consult the local Johnson Controls office. Johnson Controls, Inc. shall not be liable for damage resulting from misapplication or misuse of its products.



Building Efficiency

507 E. Michigan Street, Milwaukee, WI 53202

Metasys® and Johnson Controls® are registered trademarks of Johnson Controls, Inc. All other marks herein are the marks of their respective owners. © 2010 Johnson Controls, Inc.