

# Surface-Mounted NS Series Network Sensors with LCD

## Installation Instructions

NS-AHA700x-0, NS-AHB700x-0, NS-AHR700x-0, NS-APA700x-0,  
NS-APB700x-0, NS-APR700x-0, NS-ATA700x-0, NS-ATB700x-0,  
NS-ATC700x-0, NS-ATD700x-0, NS-ATF700x-0, NS-ATV700x-0

Part No. 24-10094-9, Rev. D

Release 5.0

Issued January 4, 2010

Supersedes October 6, 2008

### Applications

The surface-mounted NS Series Network Sensor with Liquid Crystal Display (LCD) is an electronic zone sensor designed to function directly with Johnson Controls® BACnet®

Master-Slave/Token-Passing (MS/TP) digital controllers in Heating, Ventilating, and Air Conditioning (HVAC) systems. Models in this series monitor the temperature setpoint, zone temperature, and humidity, and transmit this data to a field controller on the Sensor Actuator (SA) Bus.

Some models feature a temperature setpoint dial, and all models feature an LCD designed to make adjusting the temperature setpoint and viewing the zone temperature easier. A warmer/cooler dial is included on certain models for minor temperature adjustments from the setpoint. Some models also allow occupants to view the Relative Humidity (RH) of the zone; these models include a push button to toggle between temperature and RH on the display. A °F/°C push button is available on certain models to provide temperature scale options for display. A fan mode push button is also included on some models to select the desired fan speed (AUTO-OFF-low-medium-high). An occupancy override function is featured on all models, which allows the user to signal the controller that the space is occupied, to request an override of time-of-day scheduling. Rotating the setpoint dial signals occupancy.

Select models in this series also provide Variable Air Volume (VAV) balancing functionality. These models look like and perform similarly to the other network sensors but have the added capability of serving as a tool to balance a VAV box.

Depending on the model chosen, the wires connecting the network sensor to the controller can be terminated using either a modular jack or screw terminal block, offering wiring flexibility.

**Note:** Models featuring a modular jack are not intended for installations where daisy chaining to the MS/TP Bus is required.

All models include an SA Bus access port for connecting accessories to access the SA Bus. This feature allows a technician to commission or service the controller via the network sensor.

**IMPORTANT:** The surface-mounted NS Series Network Sensor is intended to provide an input to equipment under normal operating conditions. Where failure or malfunction of the network sensor could lead to personal injury or property damage to the controlled equipment or other property, additional precautions must be designed into the control system. Incorporate and maintain other devices, such as supervisory or alarm systems or safety or limit controls, intended to warn of or protect against failure or malfunction of the network sensor.

### North American Emissions Compliance

#### United States

This equipment has been tested and found to comply with the limits for a Class A digital device pursuant to Part 15 of the FCC Rules. These limits are designed to provide reasonable protection against harmful interference when this equipment is operated in a commercial environment. This equipment generates, uses, and can radiate radio frequency energy and, if not installed and used in accordance with the instruction manual, may cause harmful interference to radio communications. Operation of this equipment in a residential area is likely to cause harmful interference, in which case the user will be required to correct the interference at his/her own expense.

#### Canada

This Class (A) digital apparatus meets all the requirements of the Canadian Interference-Causing Equipment Regulations.

Cet appareil numérique de la Classe (A) respecte toutes les exigences du Règlement sur le matériel brouilleur du Canada.

## Installation

### Special Tools Needed

A 1/16 in. (1.5 mm) Allen wrench or a Johnson Controls T-4000-119 Allen-Head Adjustment Tool is required during installation.

## Mounting

### Location Considerations

Locate the network sensor:

- on a partitioning wall, approximately 5 ft (1.5 m) above the floor in a location of average temperature
- away from direct sunlight, radiant heat, outside walls, outside doors, air discharge grills, or stairwells; and from behind doors
- away from steam or water pipes, warm air stacks, unconditioned areas (not heated or cooled), or sources of electrical interference

**Note:** The network sensor is shock and vibration resistant; however, be careful not to drop the unit or mount it where it could be exposed to excessive vibration.

The following ambient operating conditions apply:

- Temperature: 32 to 104°F (0 to 40°C)
- Humidity: 10 to 90% Relative Humidity (RH), noncondensing; 85°F (29°C) maximum dew point

To mount the network sensor to the wall:

1. Use a 1/16 in. (1.5 mm) Allen wrench or Johnson Controls T-4000-119 Allen-Head Adjustment Tool to loosen the security screw on the top of the unit.
2. Insert a blade screwdriver or coin into the slot next to the security screw location, then carefully pry the top edge of the sensor assembly away from its mounting base and remove.

**IMPORTANT:** Do not remove the Printed Circuit Board (PCB). Removing the PCB voids the product warranty.

3. Pull out approximately 6 in. (152 mm) of cable from the wall, and insert the cable through the hole in the mounting base.
4. Align the mounting base on the wall, and use the base as a template to mark the location of the two mounting holes on the surface.

**Note:** Confirm that the mounting base is positioned with the proper edge up. The mounting base is positioned properly when the security screw is located on the top edge of the base.

5. Secure the mounting base to the wall using the appropriate mounting hardware (field furnished).
6. Wire the network sensor. For more details on wiring the MS/TP Communications Bus, refer to the *MS/TP Communications Bus Technical Bulletin (LIT-12011034)*.

For models featuring a modular jack, simply snap the wiring plug into the jack. See Figure 1 for modular jack pin number assignments. Modular jack models require a straight-through, one-to-one connection (not a crossover). For models featuring a screw terminal block, wire the unit as illustrated in Figure 2.



**CAUTION: Risk of Electric Shock.**

Disconnect power supply before making electrical connections to avoid electric shock.

**IMPORTANT:** Failure to adhere to these wiring details causes the network sensor to function incorrectly. You will not be able to connect to the system using the wireless commissioning converter or the handheld VAV balancing tool, and you will not be able to expand the system with future offerings.

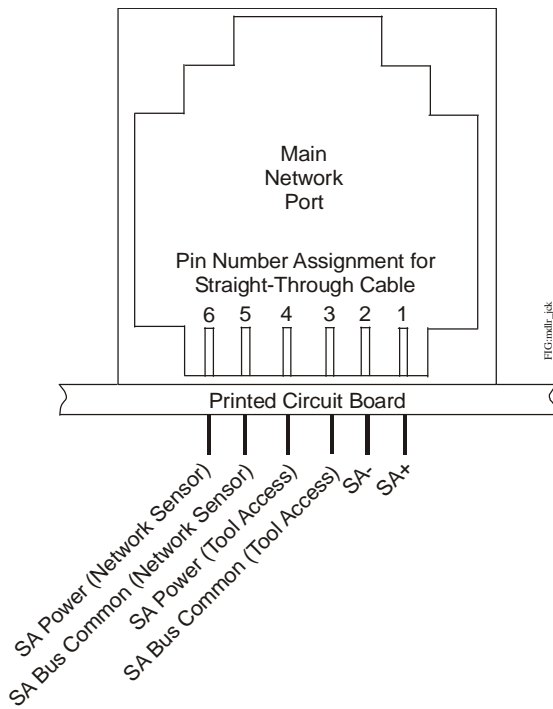

**Figure 1: Modular Jack Pin Number Assignments**

- Align the tabs on the bottom edge of the mounting base with the slots on the bottom edge of the network sensor assembly, and rotate the assembly onto its mounting base.

**Note:** On models featuring a screw terminal block, be certain that the terminal block pins align with the holes in the terminal block.

- Use a 1/16 in. (1.5 mm) Allen wrench or Johnson Controls T-4000-119 Allen-Head Adjustment Tool to tighten the security screw and fasten the network sensor assembly to the mounting base.

**Note:** Do not overtighten the security screw to avoid damaging the unit.

- Use the Controller Configuration Tool (CCT) software to commission the network sensor. Refer to the CCT *Help* for more details.

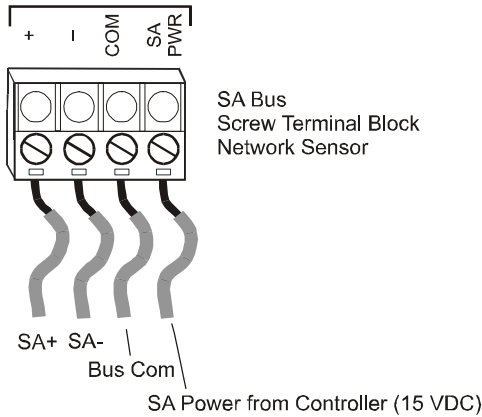

**Figure 2: Wiring to the Screw Terminal Block**

## Setup and Adjustments

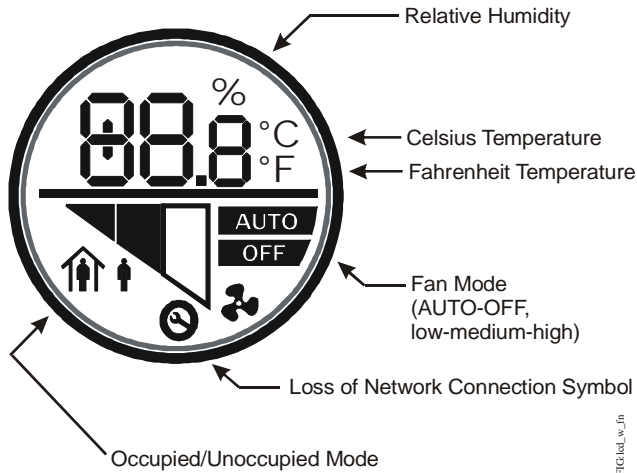

**Figure 3: LCD on Temperature/RH Models with Fan Mode Selection**

### Temperature Setpoint Adjustment/Occupancy Override

The large dial on the face of the network sensor functions in two ways: to increase or decrease the setpoint temperature, and to change the controller mode from unoccupied and occupied. When the dial is rotated, the backlight on the LCD lights up. If the controller is in the unoccupied mode, this signals it to change from the after-normal-working-hours setback mode to the normal-working-hours comfort mode. After a short pause, turn the dial in either direction to activate the setpoint and cause it to flash. Stop turning the dial once the desired setpoint is reached. The new setpoint stops flashing and becomes fixed after a few seconds.

### °F/°C Temperature Mode Selection

Certain models include a °F/°C push button on the face of the network sensor to provide temperature scale options for display. Pressing the push button toggles the temperature mode between Fahrenheit and Celsius on the LCD.

### Temperature/RH Mode Selection

Temperature/RH models include a push button on the face of the network sensor to allow occupants to view the temperature and relative humidity of the zone. Pressing the push button toggles between temperature and RH on the LCD.

### Fan Mode Selection

Some models include a fan mode push button on the face of the network sensor to select the desired fan speed. Pressing the push button toggles the fan speed between AUTO-OFF-low-medium-high on the LCD.

### Network Sensor Addressing

Most network sensors have a default device address of 199 on the SA Bus. For averaging models, the sensor address must be set on the dual-switch DIP switch block on the network sensor Printed Wire Board (PWB).

Averaging models are shipped with both switches set to ON, resulting in a device address of 203. Device addresses can be DIP switch set from 200 to 203; see Figure 4 and Table 1 for more details.

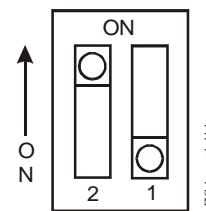

**Figure 4: Dual-Switch DIP Switch Block**

**Table 1: Network Sensor Addressing**

DIP Switch Address	Switch 2	Switch 1
200	OFF	OFF
201	OFF	ON
202	ON	OFF
203	ON	ON

### Repair Information

If the NS Series Network Sensor fails to operate within its specifications, replace the unit. For a replacement network sensor, contact the nearest Johnson Controls representative.

## Technical Specifications

### Surface-Mounted NS Series Network Sensors with Setpoint Adjustment (Part 1 of 2)

<b>Supply Voltage</b>		9.8 to 16.5 VDC; 15 VDC Nominal (From SA Bus)
<b>Current Consumption</b>		25 mA Maximum (Non-transmitting)
<b>Terminations</b>		Modular Jack or Screw Terminal Block
<b>Network Sensor Addressing</b>	<b>NS-ATx7003-0 Models</b>	DIP Switch Set from 200 to 203; Factory Set at 203
	<b>All Other Models</b>	Fixed Address of 199
<b>Wire Size</b>	<b>Modular Jack Models</b>	26 AWG (0.4 mm Diameter) Recommended; Three Twisted Pair (Six Conductors)
	<b>Screw Terminal Block Models</b>	18 to 22 AWG (1.0 to 0.6 mm Diameter); 22 AWG (0.6 mm Diameter) Recommended
<b>Communication Rate</b>		Auto-Detect: 9.6k, 19.2k, 38.4k, or 76.8k bps
<b>Temperature Measurement Range</b>		32.0°F/0.0°C to 104.0°F/40.0°C
<b>Humidity Measurement Range</b>	<b>Full Range</b>	0 to 100% RH
	<b>Calibrated Range</b>	10 to 90% RH
<b>Temperature Sensor Type</b>		Local Platinum Resistance Temperature Detector (RTD)
<b>Humidity Sensor Type</b>		Thin Film Capacitive Sensor
<b>Temperature Resolution</b>		±0.5F°/±0.5C°
<b>Temperature Sensor Accuracy</b>		±1.0F°/±0.6C°
<b>Humidity Element Accuracy</b>	<b>NS-APx700x-0 Models</b>	±2% RH for 20 to 80% RH; ±4% RH for 10 to 20% and 80 to 90% RH
	<b>NS-AHx700x-0 Models</b>	±3% RH for 20 to 80% RH; ±6% RH for 10 to 20% and 80 to 90% RH
<b>Time Constant</b>		10 Minutes Nominal at 10 fpm Airflow
<b>Default Temperature Setpoint Adjustment Range</b>		50.0°F/10.0°C to 86.0°F/30.0°C in 0.5° Increments
<b>Ambient Conditions</b>	<b>Operating</b>	32 to 104°F (0 to 40°C); 10 to 90% RH, Noncondensing; 85°F (29°C) Maximum Dew Point
	<b>Storage</b>	-4 to 140°F (-20 to 60°C); 5 to 95% RH, Noncondensing

## Surface-Mounted NS Series Network Sensors with Setpoint Adjustment (Part 2 of 2)

<b>Compliance</b>	<b>BACnet International</b>	BACnet Testing Laboratories™ (BTL) 135-2004 Listed BACnet Smart Sensor (B-SS)
	<b>United States</b>	UL Listed, File E107041, CCN PAZX, Under UL 916, Energy Management Equipment
		FCC Compliant to CFR 47, Part 15, Subpart B, Class A
	<b>Canada</b>	UL Listed, File E107041, CCN PAZX7, Under CAN/CSA C22.2 No. 205, Signal Equipment
		Industry Canada, ICES-003
	<b>Europe</b>	CE Mark, EMC Directive 2004/108/EC
		EN61000-6-3 (2001) Generic Emission Standard for Residential and Light Industry
		EN61000-6-2 (2001) Generic Immunity Standard for Heavy Industrial Environment
	<b>Australia and New Zealand</b>	C-Tick Mark, Australia/NZ Emissions Compliant
	<b>Dimensions (Height x Width x Depth)</b>	3-5/32 x 3-5/32 x 1-3/8 in. (80 x 80 x 35 mm)
<b>Shipping Weight</b>	0.20 lb (0.09 kg)	

*The performance specifications are nominal and conform to acceptable industry standards. For application at conditions beyond these specifications, consult the local office. Johnson Controls, Inc. shall not be liable for damage resulting from misapplication or misuse of its products.*



**Building Efficiency**

507 E. Michigan Street, Milwaukee, WI 53202

*Metasys® and Johnson Controls® are registered trademarks of Johnson Controls, Inc.  
All other marks herein are the marks of their respective owners. © 2010 Johnson Controls, Inc.*