

NS Series Network Discharge Air Sensors

Installation Instructions

NS-DTN7043-0, NS-DTN7083-0

Part No. 24-10336-0, Rev. D

Issued April 12, 2011

Supersedes October 4, 2010

Refer to the [QuickLIT Web site](#) for the most up-to-date version of this document.

Applications

The NS Series Network Discharge Air Sensors are electronic duct sensors designed to function directly with Johnson Controls® digital controllers in Heating, Ventilating, and Air Conditioning (HVAC) systems. Models in this series monitor the duct temperature, typically at the discharge of the Variable Air Volume (VAV) box, and transmit this data to the controller Sensor Actuator (SA) Bus using the 305 cm (10 ft) wiring lead included with the unit. The 305 cm (10 ft) wiring lead consists of four 0.6 mm (22 AWG) diameter color-coded wires encased in a plenum-rated jacket. Each of the wires is stripped and tinned for easy connection to the SA Bus screw terminal block.

The NS Series Network Discharge Air Sensors are available with either a 102 or 203 mm (4 or 8 in.) temperature probe. All models include DIP switches for applications requiring multiple discharge air sensors, each with a unique DIP switch address.

IMPORTANT: The NS Series Network Discharge Air Sensors are intended to provide an input to equipment under normal operating conditions. Where failure or malfunction of the discharge air sensors could lead to personal injury or property damage to the controlled equipment or other property, additional precautions must be designed into the control system. Incorporate and maintain other devices, such as supervisory or alarm systems or safety or limit controls, intended to warn of or protect against failure or malfunction of the discharge air sensors.

North American Emissions Compliance

United States

This equipment has been tested and found to comply with the limits for a Class A digital device pursuant to Part 15 of the FCC Rules. These limits are designed to provide reasonable protection against harmful interference when this equipment is operated in a commercial environment. This equipment generates, uses, and can radiate radio frequency energy and, if not installed and used in accordance with the instruction manual, may cause harmful interference to radio communications. Operation of this equipment in a residential area is likely to cause harmful interference, in which case the user will be required to correct the interference at his/her own expense.

Canada

This Class (A) digital apparatus meets all the requirements of the Canadian Interference-Causing Equipment Regulations.

Cet appareil numérique de la Classe (A) respecte toutes les exigences du Règlement sur le matériel brouilleur du Canada.

Mounting

The following ambient operating conditions apply:

- Temperature: -10 to 60°C (14 to 140°F)
- Humidity: 10 to 90% Relative Humidity (RH), noncondensing; 29°C (85°F) maximum dew point

Note: The discharge air sensor is shock and vibration resistant; however, be careful not to drop the unit or mount it where it could be exposed to excessive vibration.

To mount the discharge air sensor:

1. Drill a 10 mm (3/8 in.) diameter hole in the duct at the desired mounting location.
2. Insert the temperature probe into the drilled hole.
3. Secure the discharge air sensor to the duct using two No. 6 self-drilling sheet metal screws included with the unit.

Wiring

If the NS Series Network Discharge Air Sensor is used in an application requiring multiple discharge air sensors, each with a unique DIP switch address, set the DIP switches before wiring the unit. Otherwise, proceed directly to Step 5.

1. Loosen (but do not remove) the two cover-holding screws using a 6 mm (1/4 in.) blade screwdriver or a 6 mm (1/4 in.) nut driver.
2. Remove the cover from the discharge air sensor.
3. See Figure 1 and set the DIP switch block on the discharge air sensor circuit board to the desired DIP switch address.

Note: Table 1 lists the available DIP switch addresses and the DIP switch settings required to obtain them.

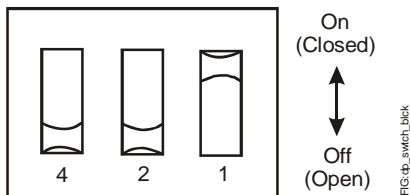

Figure 1: Setting the DIP Switch Block

Table 1: Setting the DIP Switch Address

Available DIP Switch Addresses	DIP Switch Settings		
	Switch 4	Switch 2	Switch 1
204	Off (Open)	Off (Open)	Off (Open)
205	Off (Open)	Off (Open)	On (Closed)
206	Off (Open)	On (Closed)	Off (Open)
207	Off (Open)	On (Closed)	On (Closed)
208	On (Closed)	Off (Open)	Off (Open)
209	On (Closed)	Off (Open)	On (Closed)
210	On (Closed)	On (Closed)	Off (Open)
211	On (Closed)	On (Closed)	On (Closed)

4. Reinstall the cover on the discharge air sensor and tighten the two cover-holding screws to secure it in place.
5. Wire the discharge air sensor to the SA Bus screw terminal block as illustrated in Figure 2.

Note: For more details on wiring the Master-Slave/Token-Passing (MS/TP) Communications Bus, refer to the *MS/TP Communications Bus Technical Bulletin (LIT-12011034)* or the *FX-PC Series Controllers MS/TP Communications Bus Technical Bulletin (LIT-12011670)*.



CAUTION: Risk of Electric Shock.

Disconnect the power supply before making electrical connections to avoid electric shock.

IMPORTANT: Failure to adhere to these wiring details causes the discharge air sensor to function incorrectly.

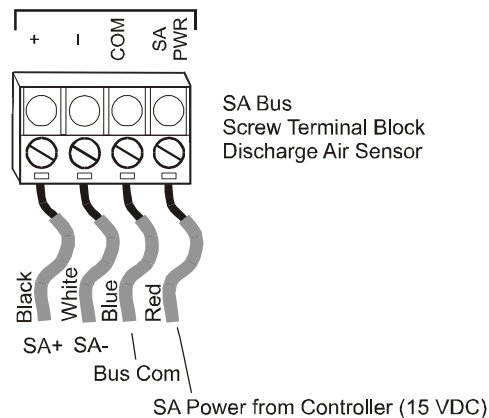

Figure 2: Wiring to the SA Bus Screw Terminal Block

6. Use the Metasys® Controller Configuration Tool (MS-CCT) or Facility Explorer Programmable Controller Tool (FX-PCT) Software to commission the discharge sensor. Refer to the *Controller Tool Help (LIT-12011147)* for more details.

Repair Information

If the NS Series Network Discharge Air Sensor fails to operate within its specifications, replace the unit. For a replacement discharge air sensor, contact the nearest Johnson Controls representative.

Technical Specifications

NS Series Network Discharge Air Sensors

Supply Voltage		9.8 to 16.5 VDC; 15 VDC Nominal
Current Consumption		12 mA Maximum (Non-transmitting) per Discharge Air Sensor; 60 mA Maximum Total Current Consumption per SA Bus
Terminations		Four Color-Coded Wiring Leads, Stripped and Tinned; Factory-Installed at the Discharge Air Sensor Screw Terminal Block
Sensor Addressing		DIP Switch Set (204 to 211); Factory Set at 204
Wire Size		1.0 to 0.6 mm (18 to 22 AWG) Diameter); 0.6 mm (22 AWG) Diameter Recommended; 305 cm (10 ft) Wiring Lead Included with the Unit
Communication Rate		Auto-Detect: 9.6k, 19.2k, 38.4k, or 76.8k bps
Temperature Measurement Range		-10°C/14°F to 60°C/140°F
Sensor Type		Local Platinum Resistance Temperature Detector (RTD)
Sensor Accuracy		±0.6C°/±1.0F°
Ambient Conditions	Operating	-10 to 60°C (14 to 140°F); 10 to 90% RH, Noncondensing; 29°C (85°F) Maximum Dew Point
	Storage	-40 to 70°C (-40 to 158°F); 5 to 95% RH, Noncondensing
Compliance CE	BACnet® International	BACnet Testing Laboratories™ (BTL) 135-2004 Listed BACnet Smart Sensor (B-SS)
	United States	UL Listed, File E107041, CCN PAZX, Under UL 916, Energy Management Equipment
		FCC Compliant to CFR 47, Part 15, Subpart B, Class A
	Canada	UL Listed, File E107041, CCN PAZX7, Under CAN/CSA C22.2 No. 205, Signal Equipment
		Industry Canada, ICES-003
	Europe	CE Mark – Johnson Controls, Inc., declares that this product is in compliance with the essential requirements and other relevant provisions of the EMC Directive 2004/108/EC.
Australia and New Zealand	C-Tick Mark, Australia/NZ Emissions Compliant	
Dimensions	Sensor Enclosure (Height x Width x Depth)	76 x 76 x 51 mm (3 x 3 x 2 in.)
	Temperature Probe	NS-DTN7043-0: 102 mm (4 in.) Long
		NS-DTN7083-0: 203 mm (8 in.) Long
Shipping Weight	NS-DTN7043-0	0.52 kg (1.15 lb)
	NS-DTN7083-0	0.53 kg (1.17 lb)

The performance specifications are nominal and conform to acceptable industry standards. For application at conditions beyond these specifications, consult the local Johnson Controls office. Johnson Controls, Inc. shall not be liable for damage resulting from misapplication or misuse of its products.



Building Efficiency
507 E. Michigan Street, Milwaukee, WI 53202

Metasys® and Johnson Controls® are registered trademarks of Johnson Controls, Inc.
All other marks herein are the marks of their respective owners. © 2011 Johnson Controls, Inc.