

TE-6300P Series Outdoor Air Temperature Sensors

Installation Instructions

TE-63xxP

Part No. 24-4034-190, Rev. C

Issued February 14, 2012

Supersedes April 6, 2010

Refer to the [QuickLIT Web site](#) for the most up-to-date version of this document.

Applications

IMPORTANT: The TE 6300P Series Outdoor Air Temperature Sensors are intended to provide an input to equipment under normal operating conditions. Where failure or malfunction of the TE-6300P sensor could lead to personal injury or property damage to the controlled equipment or other property, additional precautions must be designed into the control system. Incorporate and maintain other devices, such as supervisory or alarm systems or safety or limit controls, intended to warn of or protect against failure or malfunction of the TE-6300P sensor.

Installation

IMPORTANT: Do not install the TE-6300P Series Outdoor Air Temperature Sensor in ambient temperatures beyond the specified -50 to 122°F (-46 to 50°C) temperature range. Installing the temperature sensor in ambient temperatures beyond this range may damage the unit and void the warranty.

Dimensions

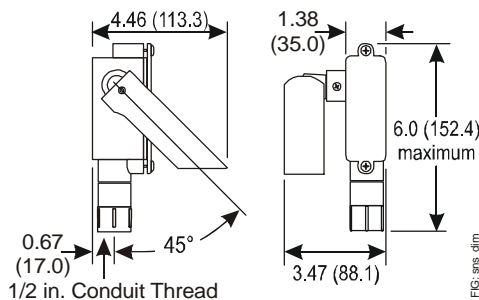

Figure 1: Outdoor Air Sensor Dimensions, in. (mm)

Mounting

Location Considerations

- Avoid areas subject to excessive vibration, electrical noise, direct sunlight, or the effects of radiant heat.
- Keep electrical wiring as short as possible to minimize temperature error.

Mounting the Temperature Sensor

See Figure 2 and mount the outdoor air temperature sensor as follows:

1. Using the 1/2-14 NPT threads, securely attach the conduit box to the conduit run.

Note: For optimal performance, attach the TE-6300P only to rigid conduit. Locate the device in the open air; do not place it in contact with the mounting surface. Secure the conduit to the mounting surface using an appropriate clamp.

2. Wire the sensor to the controller using the wire nuts provided.
3. Reposition the cover and tighten the retention screws.

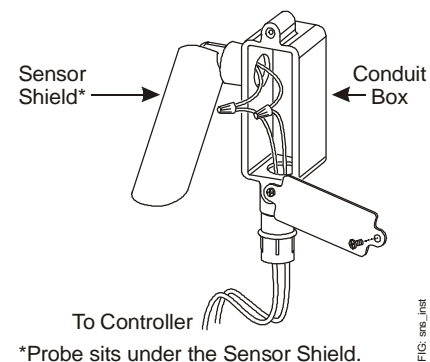

Figure 2: Installing the Outdoor Air Sensor

Wiring

For 1k ohm nickel temperature sensors, wire resistance can cause approximately 1F° (0.56C°) of error for every 250 ft (76 m) run of 18 AWG wire, or every 100 ft (31 m) run of 22 AWG wire. For 1k ohm platinum temperature sensors, wire resistance can cause approximately 1F (0.56C) of error for every 150 ft (46 m) run of 18 AWG wire, or every 50 ft (15 m) run of 22 AWG wire. To minimize error due to field wiring, limit the total resistance of all nickel temperature sensor wiring to 3 ohms, and all platinum temperature sensor wiring to 2 ohms.

The 2.2k and 10k ohm thermistor applications permit wiring to be relatively long before wire resistance adds significantly to total resistance measured at the controller. As a general rule, a 150 ft (46 m) two-wire 18 AWG run contributes 2 ohms of error, or less than 1F° (0.56C°) error, over the sensor operating temperature range.

Refer to the appropriate controller documentation for recommended sensor wiring. See Table 1 for an explanation of the lead wiring color convention.

Table 1: Lead Wiring (22 AWG, 6 in.) Color Code

Sensor Type	Lead Color
1k ohm Nickel	White
1k ohm Platinum	White with blue stripe
2.2k ohm Thermistor	White with green stripe
10k ohm Type II Thermistor	White with green stripe



CAUTION: Risk of Property Damage

Do not apply power to the system before checking all wiring connections. Short circuited or improperly connected wires may result in permanent damage to the equipment.

IMPORTANT: Use copper conductors only. Make all wiring connections in accordance with local, national, and regional regulations. Do not exceed the TE-6300P Series Outdoor Air Temperature Sensor's electrical ratings.

Repair Information

If the TE-6300P Series Outdoor Air Temperature Sensor fails to operate within its specifications, replace the unit. For a replacement sensor, contact the nearest Johnson Controls® representative

Technical Specifications.

TE-6300 Series Outdoor Air Temperature Sensors

Models	TE-6313P-1	Thin-Film Nickel Temperature Sensor
	TE-6353P-1	Thin-Film Platinum Temperature Sensor
	TE-6343P-1	2.2k ohm Thermistor Temperature Sensor
	TE-6363P-1	10k ohm, Type II Thermistor Temperature Sensor
Sensor Reference Resistance	Nickel	1k ohms at 70°F (21°C)
	Platinum	1k ohms at 32°F (0°C)
	2.2k ohm Thermistor	2,252 ohms at 77°F (25°C)
	10k ohm Thermistor	10k ohms at 77°F (25°C)
Sensor Accuracy	Nickel	± 0.34F° at 70°F (± 0.19C° at 21°C)
	Platinum	± 0.35F° at 70°F (± 0.19C° at 21°C), DIN Class A
	2.2k ohm Thermistor	± 0.36F° (± 0.2C°) in the range: 32 to 158°F (0 to 70°C)
	10k ohm Thermistor	± 0.9F° (± 0.5C°) in the range: 32 to 158°F (0 to 70°C)
Sensor Temperature Coefficient	Nickel	Approximately 3 ohms/F° (5.4 ohms/C°)
	Platinum	Approximately 2 ohms/F° (3.9 ohms/C°) 3850 ppm/K
	2.2k ohm Thermistor	Nonlinear, Negative Temperature Coefficient (NTC)
	10k ohm Thermistor	Nonlinear, NTC, Johnson Controls Type II
Materials	Probe	1/4 in. (6.4 mm) O.D. x 3 in. (76 mm) long Stainless Steel
	Enclosure and Shield	Rigid Thermoplastic
Operating Conditions	Temperature	-50 to 122°F (-46 to 50°C)

The performance specifications are nominal and conform to acceptable industry standards. For application at conditions beyond these specifications, consult the local Johnson Controls office. Johnson Controls, Inc. shall not be liable for damages resulting from misapplication or misuse of its products.



Building Efficiency

507 E. Michigan Street, Milwaukee, WI 53202

Metasys® and Johnson Controls® are registered trademarks of Johnson Controls, Inc. All other marks herein are the marks of their respective owners. © 2012 Johnson Controls, Inc.