

DPT-2015 Differential Pressure Transmitter for VAV Box Applications

The DPT-2015 Differential Pressure Transmitter senses differential pressure in pressure independent Variable Air Volume (VAV) applications. It sends an analog signal that is proportional to velocity pressure to a VAV controller. The DPT-2015 is available mounted to an M9104 or M9106 Electric Non-spring Return Actuator or to the Johnson Controls VAV controller for reliable damper positioning in closed-loop applications.

The DPT-2015 may also be mounted alone as an independent pressure transmitter or used for damper positioning in other VAV systems. (See the M9104-AGx-2N Electric Non-spring Return Actuators Product Bulletin [LIT-2681121] or the M9106-Agx-2N0x Series Electric Non-spring Return Actuators Product Bulletin [LIT-2681126] and the Variable Air Volume [VAV] Controller Technical Bulletin [LIT-6363040] for more information on these products.)

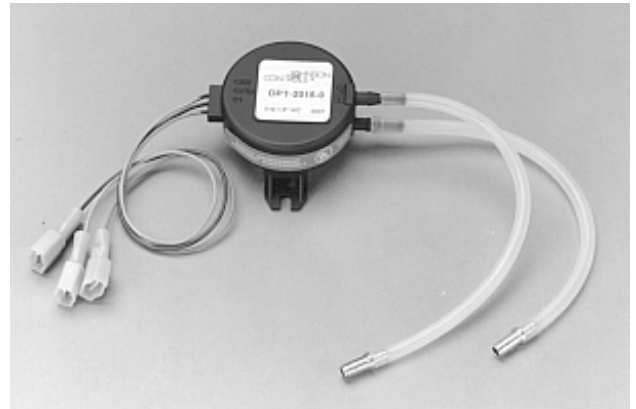

Figure 1: DPT-2015 Differential Pressure Transmitter

Features and Benefits	
<input type="checkbox"/> Integral Pressure Transmitter with Dead Ended Input Ports	Eliminates an inline filter and maintenance; prevents sensor contamination
<input type="checkbox"/> 0 to 1.5 in. Water Column (W.C.) Input Pressure Range	Satisfies the requirements for virtually all terminal box applications
<input type="checkbox"/> 0.5 to 4.5 VDC Output	Provides compatibility with a wide variety of Heating, Ventilating, and Air Conditioning (HVAC) controllers
<input type="checkbox"/> No Warmup Period	Allows for immediate commissioning after power up
<input type="checkbox"/> Capacitive Sensor Technology	Provides long-term stability and accuracy
<input type="checkbox"/> 4 VDC Output Span	Replaces DPT-2000-2 when used as recommended

Product Overview

The DPT-2015 is connected to the VAV box airflow pickups. The DPT-2015 measures differential pressure and generates a proportional voltage signal. The voltage signal from the DPT-2015 is read by the VAV controller and converted to airflow in cubic feet per minute (cfm). Calibration is not required other than zero calibration, which is performed within the controller.

Application

The DPT-2015 is used to measure differential pressure to determine the air velocity for calculating airflow. The DPT-2015 is available factory mounted to an M9104 or M9106 actuator or factory mounted to a Johnson Controls VAV controller as an AS-VAVDPT. Figure 2 shows the DPT-2015 field mounted to a M9104 or M9106 actuator. It may also be mounted separately as shown in Figure 3.

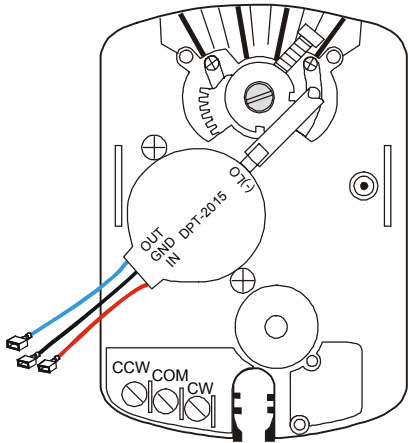

Figure 2: DPT-2015 Mounted on an M9104 or M9106 Actuator

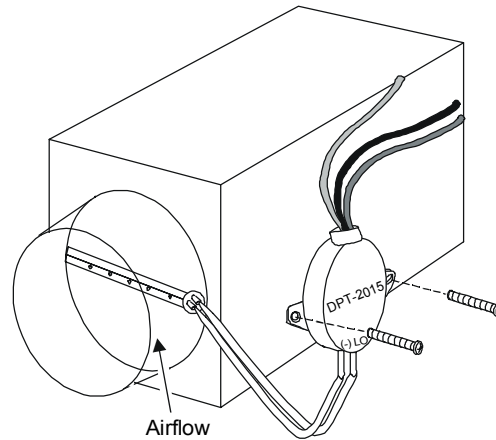

Figure 3: Typical Standalone Installation

The DPT-2015 may be used with the Johnson Controls VAV controller (as shown in Figure 4) or any other controller capable of the following:

- controller provided or external power supply of 15 VDC for input power to the DPT-2015
- 25,000 ohm minimum input impedance to accept input of 0.5 to 4.5 VDC from the output of the DPT-2015

Note: For best results, select a controller with auto zero capability.

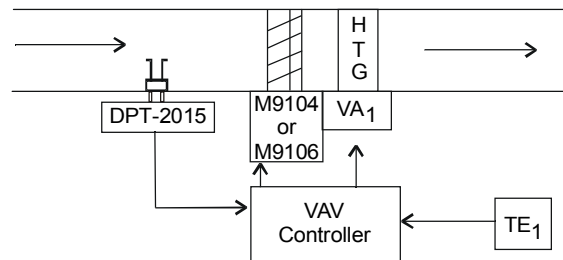

Figure 4: DPT-2015 Typical Applications

Dimensions

See Figure 5 for transmitter dimensions.

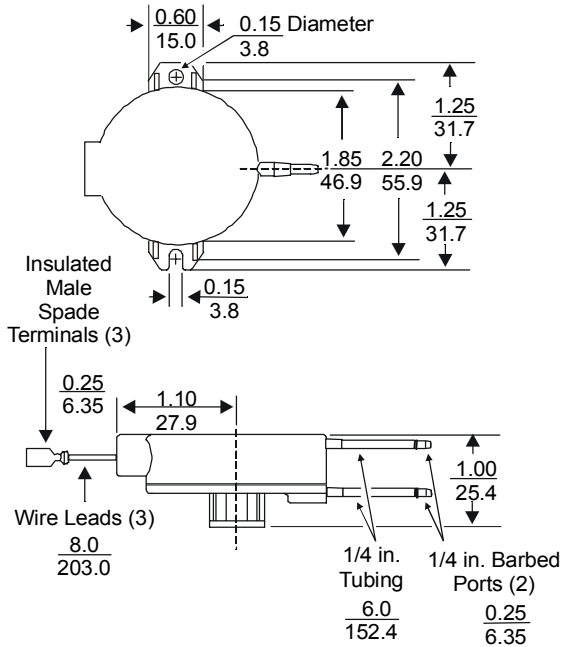

Figure 5: DPT-2015 Dimensions, in. (mm)

Repairs and Replacement

Field repairs must not be made. For a replacement or an accessory, refer to the *Ordering Information* section.

Ordering Information

Contact the nearest Johnson Controls representative, and specify the desired product code number from Table 1 or 2.

Table 1: Transmitters

Product Code Number	Description
DPT-2015-0	0 to 1.5 in. W.C. (0 to 374 Pa) differential pressure transmitter
DPT-2015-1	DPT-2015-0 with the DPT-2015-MNT Mounting Kit

Table 2: Products Available

Product Code Number	Description
CBL-2000-1	20 in. (0.5 m) wiring harness, accepted by Underwriters Laboratories, Inc.® (UL) for plenum use, is included with the M9104-AGS-2N or M9106-AGX-2N02 and may be ordered separately; connects the DPT-2015 and actuator to the VAV controller.
CBL-2000-2	20 in. (0.5 m) plenum rated wiring harness connects the DPT-2015 and M9104-AGS-2N or M9106-AGS-2N02 to the VAV controller.
CBL-2000-3	72 in. (1.8 m) plenum rated wiring harness connects the DPT-2015 and M9104-AGS-2N or M9106-AGS-2N02 to the VAV controller.
DPT-2015-MNT	Mounting kit for DPT-2015 used to replace the DPT-2000 or retrofit to the EDA-2040 without mounting bosses (date code prior to 9540).

Technical Data

Product	DPT-2015 Differential Pressure Transmitter for VAV Box Applications
Power Requirements	15 VDC (14.5 to 17 VDC) unregulated; 15 mA maximum
Pressure Range	0 to 1.5 in. W.C. (0 to 374 Pa) maximum
Overpressure Limit	15 in. W.C. (3.74 kPa)
Output Voltage	0.5 to 4.5 VDC into load impedance of 25,000 ohms minimum
Accuracy Linearity	Linearity: $\pm 1.0\%$ full span maximum Repeatability/Hysteresis: $\pm 0.05\%$ full span maximum
Position Effects	Zero Shift: ± 0.1 VDC maximum Span Shift: ± 0.05 VDC maximum
Stability (One Year)	Zero Shift: $\pm 0.5\%$ full span Span Shift: $\pm 2\%$ full span
Temperature Effects	Zero: $\pm 0.06\%$ of full span per F° maximum over 60 to 120°F (15.6 to 49.0°C) range Span: $\pm 1.5\%$ of full span maximum over 60 to 120°F (15.6 to 49.0°C) range
Power Supply Effects	For power supply changes of 14.5 to 17.1 VDC, referenced to 15.0 VDC Zero Shift: ± 0.01 VDC maximum Span Shift: +0.02, -0.04 VDC maximum
Terminals	1/4 in. male spade terminals with 8 in. (203 mm) wire length
Pressure Connections	6 in. (152 mm) length of silicone tubing with barbed fittings for 1/4 in. (6.35 mm) O.D. tubing
Ambient Operating Conditions	32 to 140°F (0 to 60°C) 90% RH maximum, non-condensing
Ambient Storage Conditions	-22 to 185°F (-30 to 85°C) 90% RH maximum, non-condensing
Dimensions (H x W x D)	1.00 x 2.71 x 2.5 in. (25.4 x 68.8 x 63.5 mm)
Shipping Weight	2.5 oz. (0.07 kg)
Agency Compliance	UL 916 Listed, File E107041, CCN PAZX CSA C22.2, No. 205 Certified, File LR68965, Class 4812 05

The performance specifications are nominal and conform to acceptable industry standards. For application at conditions beyond these specifications, consult the local Johnson Controls office. Johnson Controls, Inc. shall not be liable for damages resulting from misapplication or misuse of its products.



Controls Group
507 E. Michigan Street
P.O. Box 423
Milwaukee, WI 53201

www.johnsoncontrols.com
Printed in U.S.A.