



RLD-H10PRO Refrigerant Leak Detector

Product Bulletin

Code No. LIT-12012073
 Issued April 29, 2015

Refer to the [QuickLIT website](#) for the most up-to-date version of this document.

The RLD-H10PRO is a professional-grade leak detector for use by refrigeration and air conditioning technicians. This detector senses all CFC, HCFC, and HFC refrigerants and blends, such as R12, R22, R134a, R404a, R410a, R502, and R507 among others. The RLD-H10PRO is self-powered with a rechargeable battery and provides both manual and automatic compensation for background levels of refrigerant. A full line of accessories and maintenance kits are also available, including replacement sensors, tuneup kits, probe extensions, battery chargers, and leak vial bottles.

Growing concern over the effects of certain refrigerants on the atmosphere has generated a strong motive to eliminate system leaks and to develop safer refrigerants. With the RLD-H10PRO Refrigerant Leak Detector, you can be confident that your instrument will provide the sensitivity and capabilities to meet your service needs today and for the years to come.

The RLD-H10PRO is intended principally as a service technician's tool. This detector has the capability to detect small amounts of halogenated gases, including chlorine and fluorine-based refrigerants and blends.



Figure 1: RLD-H10PRO Refrigerant Leak Detector

Table 1: Features and Benefits

Features	Benefits
Positive Ion Emission Heated Diode Sensor	Provides the most sensitivity available today, while still detecting all halogenated refrigerant gases.
Rechargeable Battery with Low and Full Charge LEDs	Enhances portability—no external power required.
High Quality Air Pump	Supplies constant airflow to the sensor so it responds quickly to leaks; also helps the sensor recover quickly after exposure to a refrigerant so the leak can be verified.
Switchable Adjustment for Manual or Automatic Balance	Allows users to choose their preferred method of compensation for background refrigerant levels.
Visual and Audible Signal	Facilitates sensing in noisy equipment rooms with 360° visibility and a piercing tone. Frequency of noise and light indicates the magnitude of the leak.
Headset Jack	Allows users to hear the leak detector response in noisy environments.
External Calibration Source and Calibration Indicators	Indicate when the sensor is working properly and serve as reference points to judge leak size.

Operation

The leak detector consists of a control unit with a manual balance adjustment and an auto-balancing circuit, a probe with a 4.5 foot cable, a rechargeable battery, and a battery charger housed in a shock-resistant molded polyethylene case with a detachable strap. The sensor uses positive ion emission technology, which is based on the ionization characteristics of alkali metals. The alkali metals act as the cathode of a diode, and the anode is heated by a DC voltage. Air from the area being leak checked is pumped from the probe and into the space between the cathode and anode. If halogen gas is present, it creates an ionized current between the cathode and the anode, which is amplified to emit an alarm and light an LED in the clear probe tip. Sensitivity can be controlled by adjusting the amount of current through the sensor (the sensor temperature).

Dimensions

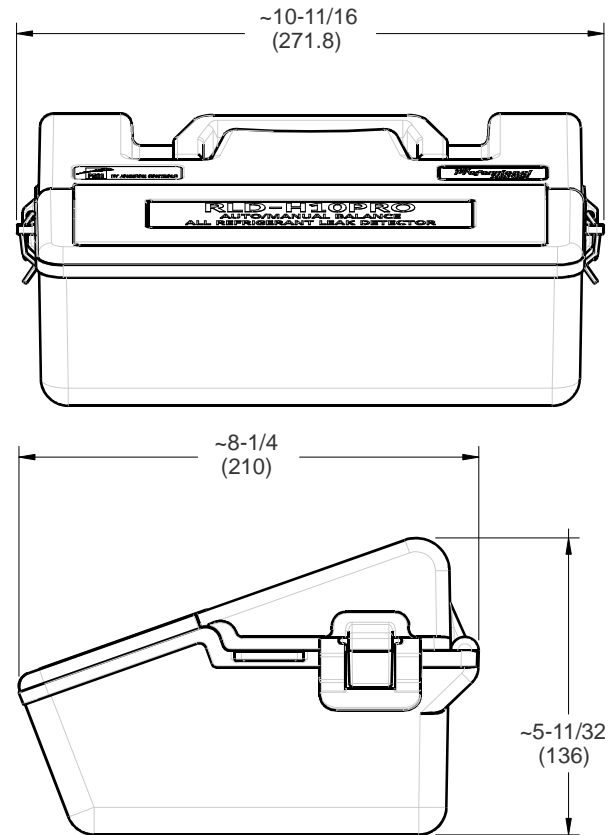

Figure 2: RLD-H10PRO Dimensions, in. (mm)

Ordering Information

RLD-H10PRO Ordering Information

Product Code Number	Description
RLD-H10PRO-1	Refrigerant leak detector and charger
RLD-H10-100	14 inch flexible probe extension
RLD-H10-102	Cigarette lighter adapter (charges or operates leak detector from vehicle's cigarette lighter)
RLD-H10-103	Replacement battery charger
RLD-H10-105	Belt pack battery (extends the operation of the RLD-H10PRO for an additional 3 hours of consecutive use; conveniently straps to your waist; includes its own charger)
RLD-H10-600R	Tuneup kit: Includes sensor, 100 filters, 3 airflow balls, 3 rubber probe tips, and leak vial
RLD-H10-601R	Replacement sensor
RLD-H10-602R	Maintenance kit: Includes 100 filters, 3 airflow balls, 3 rubber probe tips, and leak vial
RLD-H10-603R	Replacement leak vial (contains enough refrigerant to last approximately 6 months)
RLD-H10-604R	Replacement for RLD-H10PRO internal battery
RLD-H10-606R	Clear plastic probe tip (replaces clear plastic section of scratched or cracked probe tips)
RLD-H10-607R	Probe replacement assembly (snaps on to air pump and has quick connects for power to LED; replaces entire probe assembly for the RLD-H10PRO)

Technical Specifications

RLD-H10PRO Refrigerant Leak Detector

Power Requirements	12 VDC internal battery, or 100 to 240 VAC input/18 V output wall adapter (included) (RLD-H10-101).	
Sensing Element Type	Positive ion emission heated diode	
Approximate Sensitivity¹	Stationary	0.006 oz./yr
	Moving (Per SAE J2791)	0.1 oz./yr
Automatic Background Adjustment	Mode selection for automatic or manual background zeroing Note: Manual background zeroing provides the best sensitivity.	
Leak Alarm	Audible alarm (through internal beeper or stereo headphone jack), visible red LED	
Response Time	Approximately 1 second	
Warmup Time	Approximately 2 minutes	
Probe Length	Approximately 4.5 ft (1.4 m)	
Ambient Operating Conditions	32 to 104°F (0 to 40°C); 5-90% RH, noncondensing	
Ambient Storage Conditions	14 to 140°F (-10 to 60°C); 5-90% RH, noncondensing	
Case	Rugged high-density polyethylene	
Dimensions (H x W x D)	5.4 x 10.5 x 8.3 in. (137 x 267 x 211 mm)	
Compliance 	Europe: CE Mark Johnson Controls, Inc. declares that this product is in compliance with the essential requirements and other relevant provisions of the EMC Directive.	
Shipping Weight	5.1 lb (2.3 kg)	

1. Sensitivity for R12, R22, R134a, R410a, R404a, and R507 when unit is set to small leak setting, manual mode.

The performance specifications are nominal and conform to acceptable industry standards. For application at conditions beyond these specifications, consult the local Johnson Controls office. Johnson Controls, Inc. shall not be liable for damages resulting from misapplication or misuse of its products.



Building Efficiency
507 E. Michigan Street, Milwaukee, WI 53202
© Johnson Controls and PENN are registered trademarks of Johnson Controls, Inc. in the United States of America and/or other countries. All other trademarks used herein are the property of their respective owners. © Copyright 2015 by Johnson Controls, Inc. All rights reserved.